

# HIKOKI

---

## C 3606DPA

---

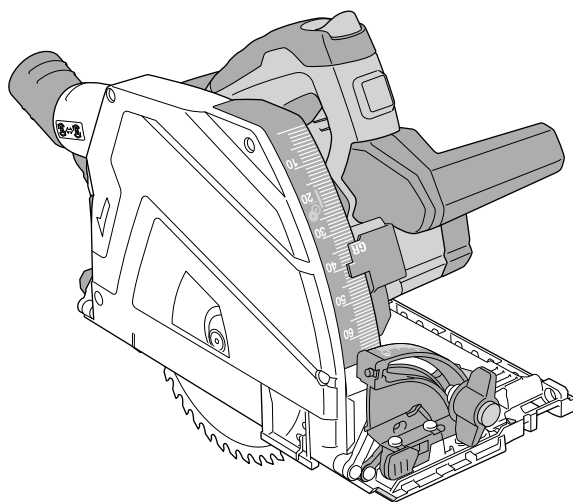

Handling instructions

1

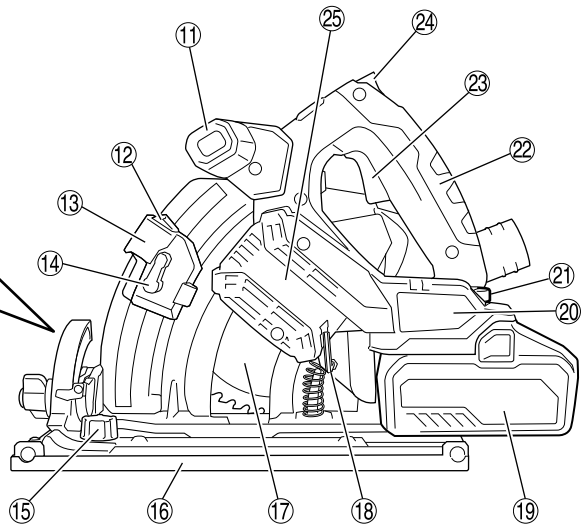
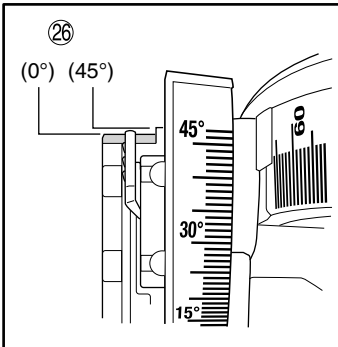
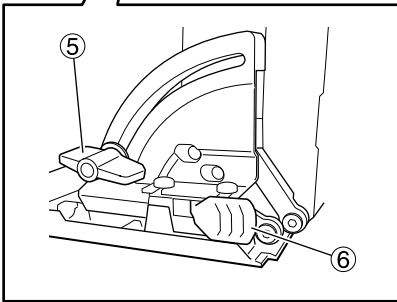
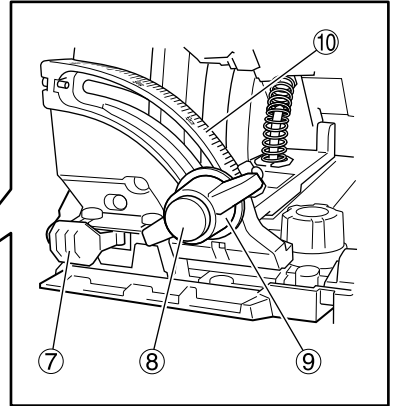
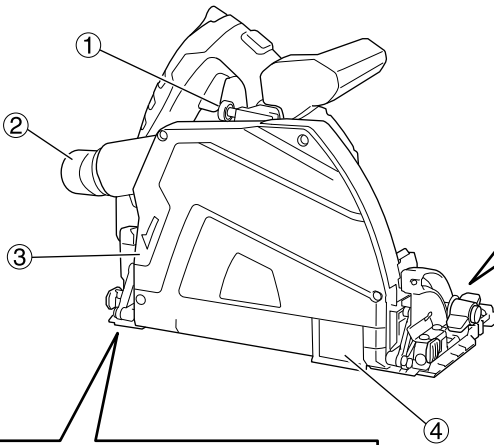

2

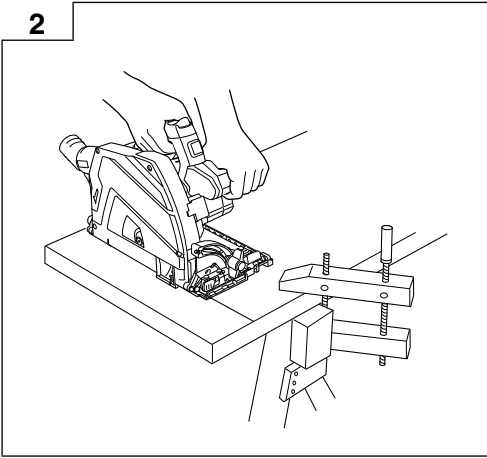

3

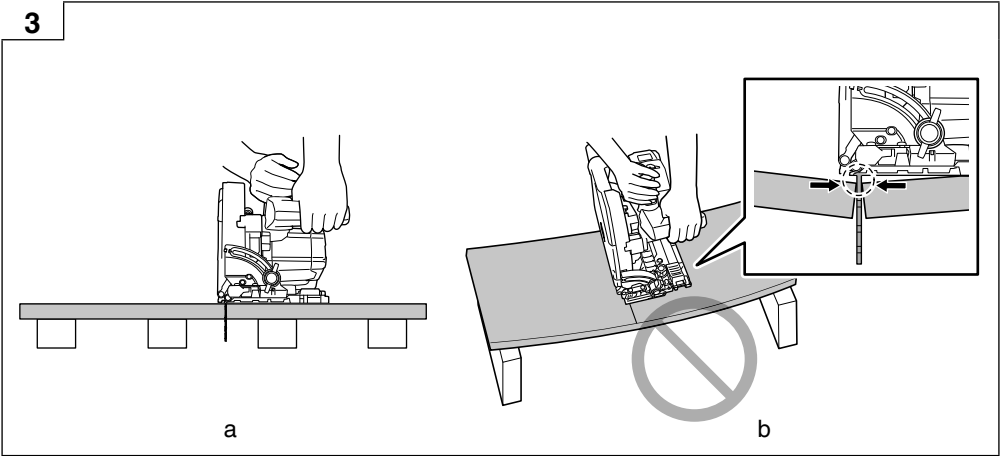

4

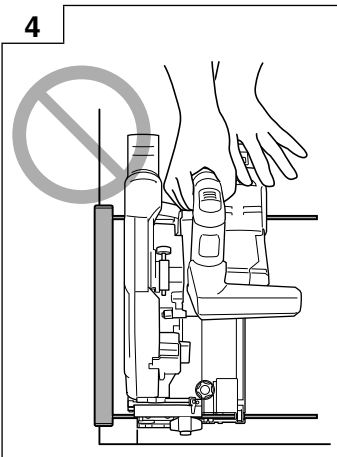



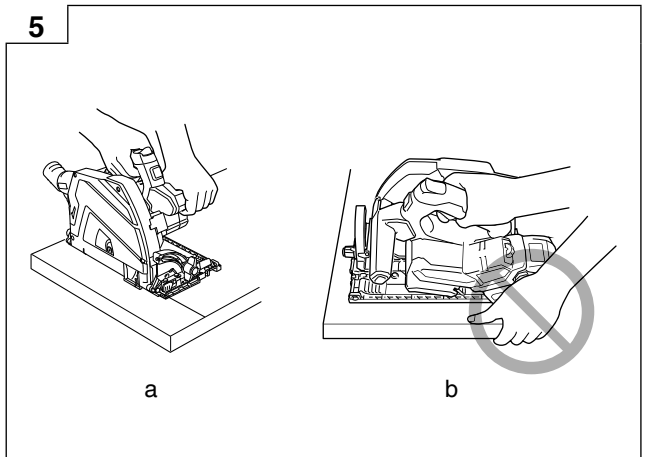

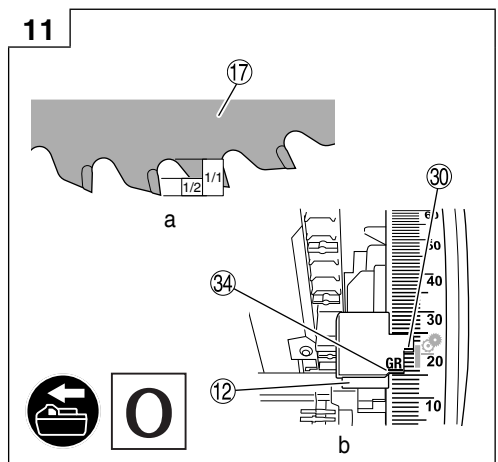
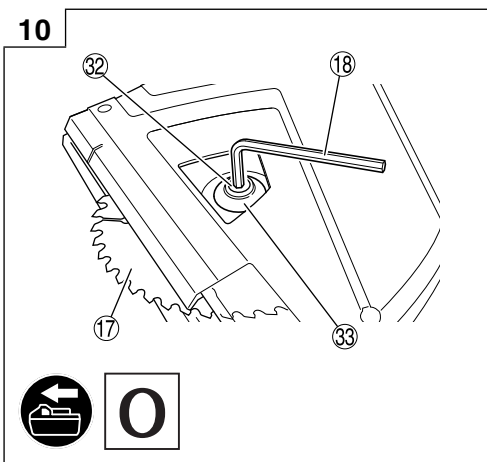
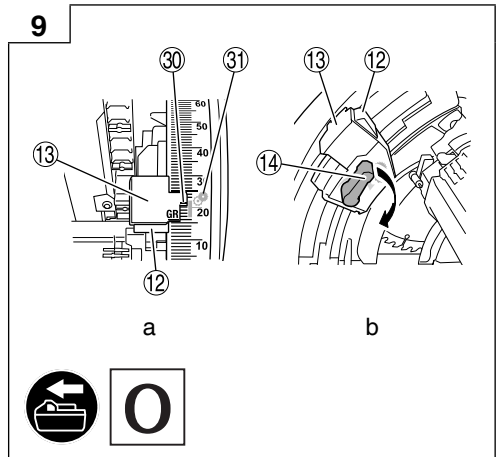
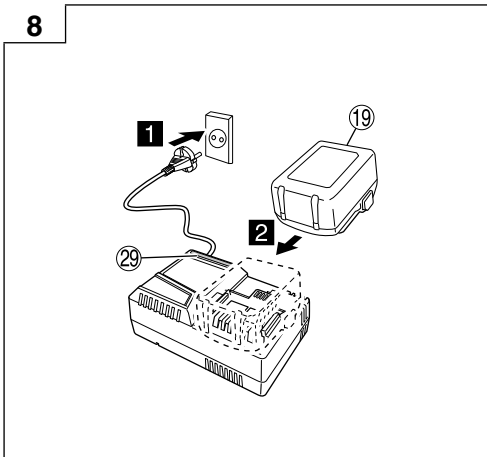
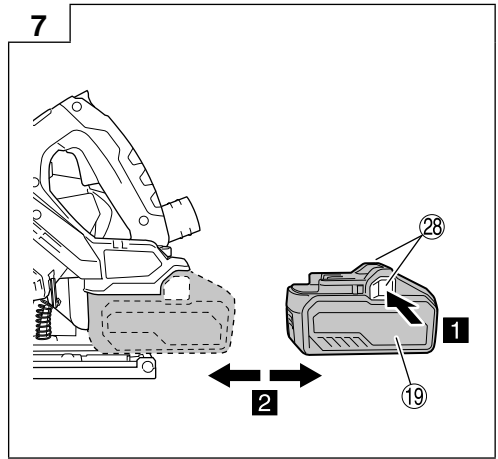
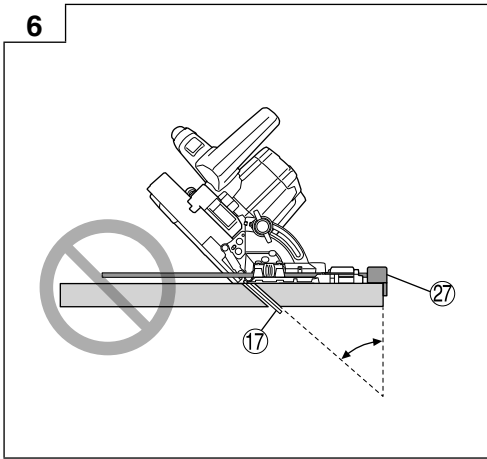

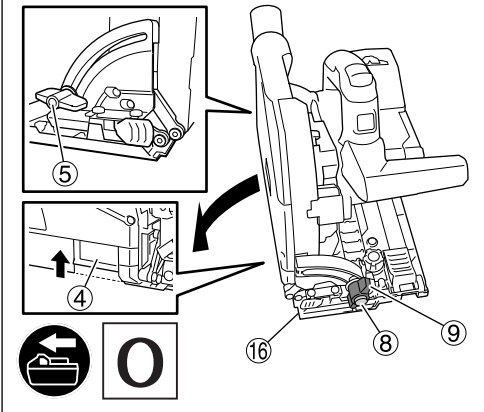
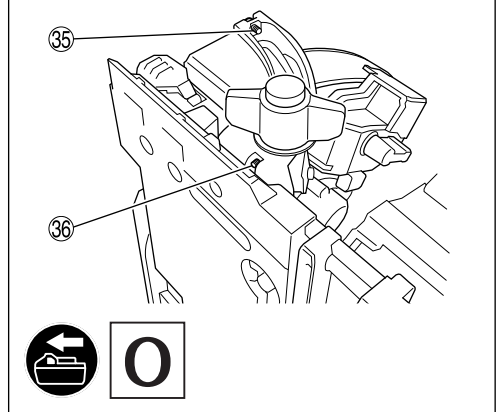
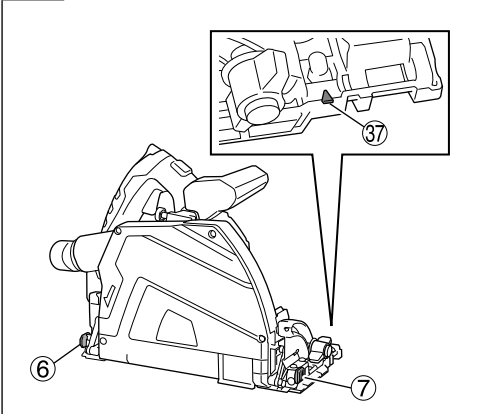
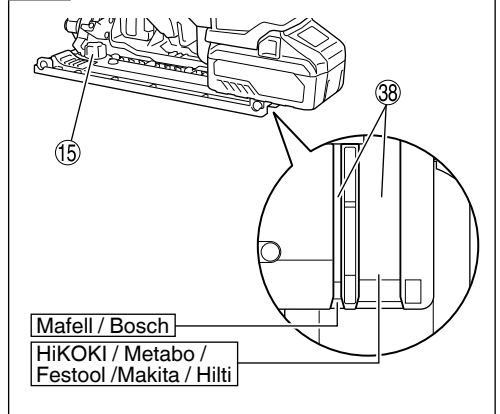
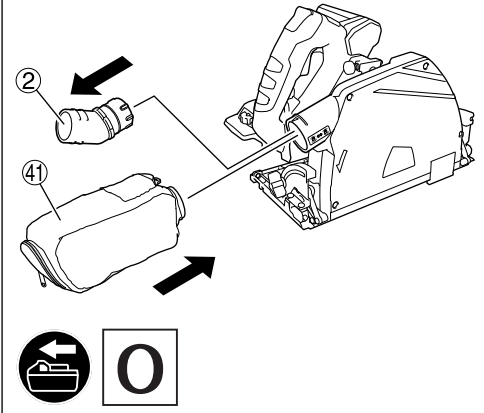
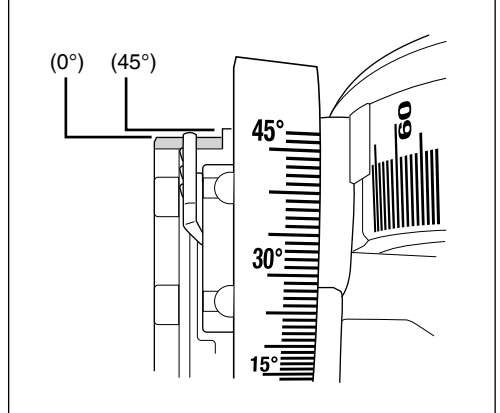
5





**12****13****14****15****16****17**

18

②1		②1	
	/min		
12	5200	12	
11	4950	12	
10	4700	12	
9	4450	12	
8	4200	4-8	PVC...
7	3950	4-8	PLEXI
6	3700	4-8	GIPS
5	3450	4-8	ALU
4	3200		
3	2950		
2	2700		
1	2500		

19

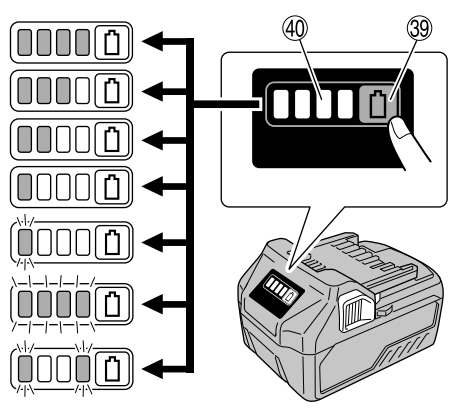

20

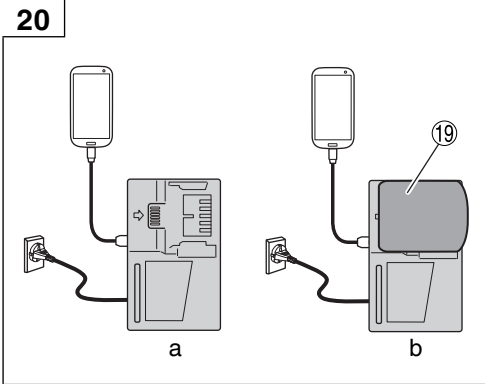

21

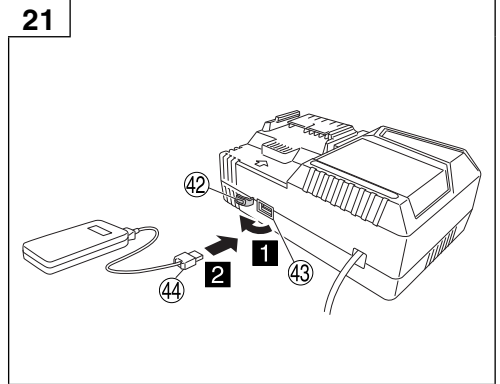

22

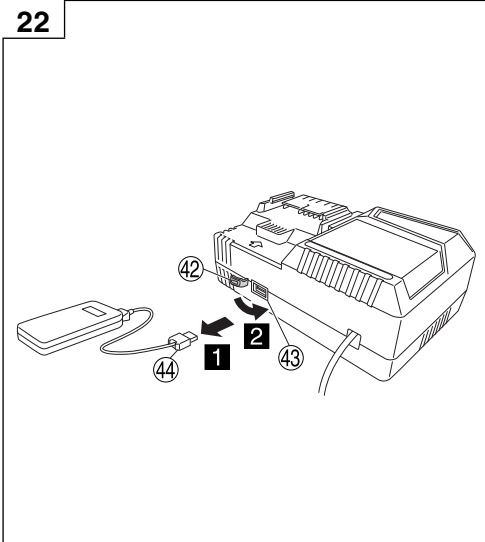

23

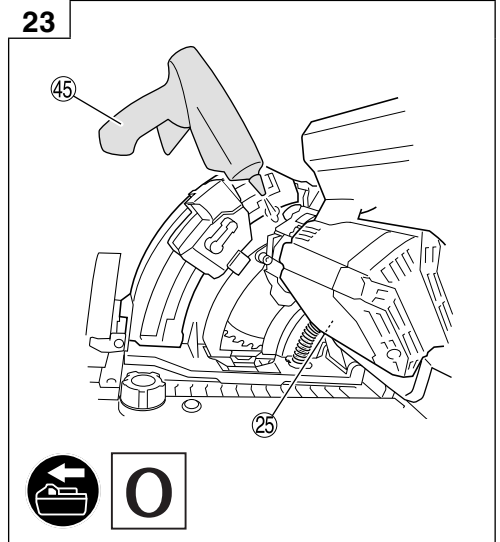

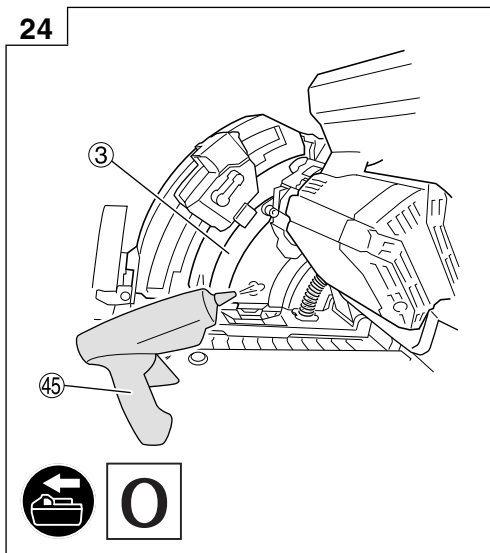

## GENERAL POWER TOOL SAFETY WARNINGS

### WARNING

Read all safety warnings, instructions, illustrations and specifications provided with this power tool.

Failure to follow all instructions listed below may result in electric shock, fire and/or serious injury.

Save all warnings and instructions for future reference.

The term "power tool" in the warnings refers to your mains-operated (corded) power tool or battery-operated (cordless) power tool.

#### 1) Work area safety

- a) **Keep work area clean and well lit.**  
*Cluttered or dark areas invite accidents.*
- b) **Do not operate power tools in explosive atmospheres, such as in the presence of flammable liquids, gases or dust.**  
*Power tools create sparks which may ignite the dust or fumes.*
- c) **Keep children and bystanders away while operating a power tool.**  
*Distractions can cause you to lose control.*

#### 2) Electrical safety

- a) **Power tool plugs must match the outlet. Never modify the plug in any way. Do not use any adapter plugs with earthed (grounded) power tools.**  
*Unmodified plugs and matching outlets will reduce risk of electric shock.*
- b) **Avoid body contact with earthed or grounded surfaces, such as pipes, radiators, ranges and refrigerators.**  
*There is an increased risk of electric shock if your body is earthed or grounded.*
- c) **Do not expose power tools to rain or wet conditions.**  
*Water entering a power tool will increase the risk of electric shock.*
- d) **Do not abuse the cord. Never use the cord for carrying, pulling or unplugging the power tool. Keep cord away from heat, oil, sharp edges or moving parts.**  
*Damaged or entangled cords increase the risk of electric shock.*
- e) **When operating a power tool outdoors, use an extension cord suitable for outdoor use.**  
*Use of a cord suitable for outdoor use reduces the risk of electric shock.*
- f) **If operating a power tool in a damp location is unavoidable, use a residual current device (RCD) protected supply.**  
*Use of an RCD reduces the risk of electric shock.*

#### 3) Personal safety

- a) **Stay alert, watch what you are doing and use common sense when operating a power tool. Do not use a power tool while you are tired or under the influence of drugs, alcohol or medication.**  
*A moment of inattention while operating power tools may result in serious personal injury.*
- b) **Use personal protective equipment. Always wear eye protection.**  
*Protective equipment such as a dust mask, non-skid safety shoes, hard hat or hearing protection used for appropriate conditions will reduce personal injuries.*

- c) **Prevent unintentional starting. Ensure the switch is in the off-position before connecting to power source and/or battery pack, picking up or carrying the tool.**

*Carrying power tools with your finger on the switch or energising power tools that have the switch on invites accidents.*

- d) **Remove any adjusting key or wrench before turning the power tool on.**  
*A wrench or a key left attached to a rotating part of the power tool may result in personal injury.*
- e) **Do not overreach. Keep proper footing and balance at all times.**  
*This enables better control of the power tool in unexpected situations.*
- f) **Dress properly. Do not wear loose clothing or jewellery. Keep your hair and clothing away from moving parts.**  
*Loose clothes, jewellery or long hair can be caught in moving parts.*
- g) **If devices are provided for the connection of dust extraction and collection facilities, ensure these are connected and properly used.**  
*Use of dust collection can reduce dust-related hazards.*
- h) **Do not let familiarity gained from frequent use of tools allow you to become complacent and ignore tool safety principles.**  
*A careless action can cause severe injury within a fraction of a second.*

#### 4) Power tool use and care

- a) **Do not force the power tool. Use the correct power tool for your application.**  
*The correct power tool will do the job better and safer at the rate for which it was designed.*
- b) **Do not use the power tool if the switch does not turn it on and off.**  
*Any power tool that cannot be controlled with the switch is dangerous and must be repaired.*
- c) **Disconnect the plug from the power source and/or remove the battery pack, if detachable, from the power tool before making any adjustments, changing accessories, or storing power tools.**  
*Such preventive safety measures reduce the risk of starting the power tool accidentally.*
- d) **Store idle power tools out of the reach of children and do not allow persons unfamiliar with the power tool or these instructions to operate the power tool.**  
*Power tools are dangerous in the hands of untrained users.*
- e) **Maintain power tools and accessories. Check for misalignment or binding of moving parts, breakage of parts and any other condition that may affect the power tool's operation. If damaged, have the power tool repaired before use.**  
*Many accidents are caused by poorly maintained power tools.*
- f) **Keep cutting tools sharp and clean.**  
*Properly maintained cutting tools with sharp cutting edges are less likely to bind and are easier to control.*
- g) **Use the power tool, accessories and tool bits etc. in accordance with these instructions, taking into account the working conditions and the work to be performed.**  
*Use of the power tool for operations different from those intended could result in a hazardous situation.*
- h) **Keep handles and grasping surfaces dry, clean and free from oil and grease.**  
*Slippery handles and grasping surfaces do not allow for safe handling and control of the tool in unexpected situations.*



- 5) **Battery tool use and care**
- Recharge only with the charger specified by the manufacturer.**  
*A charger that is suitable for one type of battery pack may create a risk of fire when used with another battery pack.*
  - Use power tools only with specifically designated battery packs.**  
*Use of any other battery packs may create a risk of injury and fire.*
  - When battery pack is not in use, keep it away from other metal objects, like paper clips, coins, keys, nails, screws or other small metal objects, that can make a connection from one terminal to another.**  
*Shorting the battery terminals together may cause burns or a fire.*
  - Under abusive conditions, liquid may be ejected from the battery; avoid contact. If contact accidentally occurs, flush with water. If liquid contacts eyes, additionally seek medical help.**  
*Liquid ejected from the battery may cause irritation or burns.*
  - Do not use a battery pack or tool that is damaged or modified.**  
*Damaged or modified batteries may exhibit unpredictable behaviour resulting in fire, explosion or risk of injury.*
  - Do not expose a battery pack or tool to fire or excessive temperature.**  
*Exposure to fire or temperature above 130°C may cause explosion.*
  - Follow all charging instructions and do not charge the battery pack or tool outside the temperature range specified in the instructions.**  
*Charging improperly or at temperatures outside the specified range may damage the battery and increase the risk of fire.*
- 6) **Service**
- Have your power tool serviced by a qualified repair person using only identical replacement parts.**  
*This will ensure that the safety of the power tool is maintained.*
  - Never service damaged battery packs.**  
*Service of battery packs should only be performed by the manufacturer or authorized service providers.*

#### PRECAUTION

Keep children and infirm persons away.  
When not in use, tools should be stored out of reach of children and infirm persons.

## CORDLESS PLUNGE CUT SAW SAFETY WARNINGS

### Cutting procedures

- ⚠ DANGER: Keep hands away from cutting area and the blade. Keep your second hand on auxiliary handle, or motor housing.**  
*If both hands are holding the saw, they cannot be cut by the blade.*
- Do not reach underneath the workpiece.**  
*The guard cannot protect you from the blade below the workpiece.*
- Adjust the cutting depth to the thickness of the workpiece.**  
*Less than a full tooth of the blade teeth should be visible below the workpiece.*

- Never hold the workpiece in your hands or across your leg while cutting. Secure the workpiece to a stable platform.**  
*It is important to support the work properly to minimize body exposure, blade binding, or loss of control.*
- Hold the power tool by insulated gripping surfaces, when performing an operation where the cutting tool may contact hidden wiring.**  
*Contact with a "live" wire will also make exposed metal parts of the power tool "live" and could give the operator an electric shock.*
- When ripping, always use a rip fence or straight edge guide.**  
*This improves the accuracy of cut and reduces the chance of blade binding.*
- Always use blades with correct size and shape (diamond versus round) of arbour holes.**  
*Blades that do not match the mounting hardware of the saw will run off-centre, causing loss of control.*
- Never use damaged or incorrect blade washers or bolt.**  
*The blade washers and bolt were specially designed for your saw, for optimum performance and safety of operation.*

### Kickback causes and related warnings

- kickback is a sudden reaction to a pinched, jammed or misaligned saw blade, causing an uncontrolled saw to lift up and out of the workpiece toward the operator;
  - when the blade is pinched or jammed tightly by the kerf closing down, the blade stalls and the motor reaction drives the unit rapidly back toward the operator;
  - if the blade becomes twisted or misaligned in the cut, the teeth at the back edge of the blade can dig into the top surface of the wood causing the blade to climb out of the kerf and jump back toward the operator.
- Kickback is the result of saw misuse and/or incorrect operating procedures or conditions and can be avoided by taking proper precautions as given below.

- Maintain a firm grip with both hands on the saw and position your arms to resist kickback forces. Position your body to either side of the blade, but not in line with the blade.**  
*Kickback could cause the saw to jump backwards, but kickback forces can be controlled by the operator, if proper precautions are taken.*
- When blade is binding, or when interrupting a cut for any reason, release the trigger and hold the saw motionless in the material until the blade comes to a complete stop.**  
**Never attempt to remove the saw from the work or pull the saw backward while the blade is in motion or kickback may occur.**  
*Investigate and take corrective actions to eliminate the cause of blade binding.*
- When restarting a saw in the workpiece, centre the saw blade in the kerf so that the saw teeth are not engaged into the material.**  
*If a saw blade binds, it may walk up or kickback from the workpiece as the saw is restarted.*
- Support large panels to minimise the risk of blade pinching and kickback.**  
*Large panels tend to sag under their own weight. Supports must be placed under the panel on both sides, near the line of cut and near the edge of the panel.*
- Do not use dull or damaged blades.**  
*Unsharpened or improperly set blades produce narrow kerf causing excessive friction, blade binding and kickback.*

- f) **Blade depth and bevel adjusting locking levers must be tight and secure before making the cut.**  
If blade adjustment shifts while cutting, it may cause binding and kickback.
- g) **Use extra caution when sawing into existing walls or other blind areas.**  
The protruding blade may cut objects that can cause kickback.
- Guard function**
- a) **Check the guard for proper closing before each use. Do not operate the saw if the guard does not move freely and enclose the blade instantly. Never clamp or tie the guard so that the blade is exposed.**  
If the saw is accidentally dropped, the guard may be bent. Check to make sure that the guard moves freely and does not touch the blade or any other part, in all angles and depths of cut.
- b) **Check the operation and condition of the guard return spring. If the guard and the spring are not operating properly, they must be serviced before use.** The guard may operate sluggishly due to damaged parts, gummy deposits, or a build-up of debris.
- c) **Assure that the base plate of the saw will not shift while performing a "plunge cut".** Blade shifting sideways will cause binding and likely kick back.
- d) **Always observe that the guard is covering the blade before placing the saw down on bench or floor.** An unprotected, coasting blade will cause the saw to walk backwards, cutting whatever is in its path. Be aware of the time it takes for the blade to stop after switch is released.

## ADDITIONAL SAFETY WARNINGS

- WARNING:** It is important to support the work piece properly and to hold the saw firmly to prevent loss of control which could cause personal injury. **Fig. 2** illustrates typical hand support of the saw.
- Avoid cutting in the state where the base has floated up from the material.  
When blade is binding, or when interrupting a cut for any reason, release the trigger and hold the saw motionless in the material until the blade comes to a complete stop. Never attempt to remove the saw from the work or pull the saw backward while the blade is in motion or KICKBACK may occur. Investigate and take corrective actions to eliminate the cause of blade binding.
- Support large panels to minimize the risk of blade pinching and KICKBACK. Large panels tend to sag under their own weight (**Fig. 3-b**). Supports must be placed under the panel on both sides, near the line of cut and near the edge of the panel as shown in **Fig. 3-a**. To minimize the risk of blade pinching and kickback. When cutting operation requires the resting of the saw on the work piece, the saw shall be rested on the larger portion and the smaller piece cut off.
- The protruding blade may cut objects that can cause KICKBACK.  
**NEVER** place your hand or fingers behind the saw (**Fig. 4**). If kickback occurs, the saw could easily jump backwards over your hand, possibly causing severe injury.
- Place the wider portion of the saw base on that part of the work piece which is solidly supported, not on the section that will fall off when the cut is made. As examples, **Fig. 5-a** illustrates the RIGHT way to cut off the end of board, and **Fig. 5-b** the WRONG way. If the work piece is short or small, clamp is down.  
**DON'T TRY TO HOLD SHORT PLACES BY HAND!**
- When using the guide, do not attempt an inclined cut which would allow the cut material to slip between the saw blade and guide. Doing so could result in injury. (**Fig. 6**)
- Wear earplugs to protect your ears during operation.
- Use only blade diameter specified on the machine.
- Do not use any abrasive wheel.
- Do not use saw blades which are deformed or cracked.
- Do not use saw blades made of high speed steel.
- Do not use saw blades which do not comply with the characteristics specified in these instructions.
- Do not stop the saw blades by lateral pressure on the disc.
- Always keep the saw blades sharp.
- Ensure that the retraction mechanism of the guard system operates correctly.
- Never operate the plunge cut saw with the saw blade turned upward or to the side.
- Ensure that the material is free of foreign matters such as nails.
- Pull out battery before carrying out any adjustment, servicing or maintenance.
- Be careful of brake kickback.  
This power tool features an electric brake that functions when the switch is released. As there is some kickback when the brake functions, be sure to hold the main body securely.
- Ensure that the switch is in the OFF position. If the battery installed to power tool while the switch is in the ON position, the power tool will start operating immediately, which could cause a serious accident.
- Never use a power tool with its locking screws or clamping lever loosened or with its lock lever lowered. After making adjustments, be sure to return the lock lever and other parts to their original positions.
- Prior to cutting operation, make sure the material you are going to cut. If the material to be cut is expected to generate harmful / toxic dusts, make sure the dust bag or appropriate dust extraction system is connected with dust outlet tightly.  
Wear the dust mask additionally, if available.
  - Before starting to saw, confirm that the saw blade has attained full-speed revolution.
  - Should the saw blade stop or make an abnormal noise while operating, promptly turn OFF the switch.
  - Using the plunge cut saw with the saw blade facing upwards or sideways is very hazardous. Such uncommon applications should be avoided.
  - When cutting materials, always wear protective glasses.
  - When finished with a job, pull out the battery.
- Use a saw blade with a displayed speed that is equal to or higher than the rotation speed displayed on the tool.
- Always use the tool and battery at temperatures between -5°C and 40°C.
- If you notice that the unit is generating unusually high temperatures, operating poorly, or making abnormal noises, immediately stop using and shut off the power switch. Request an inspection and repair from the dealer where you purchased the unit or a HiKOKI Authorized Service Center.  
Continuing to use while operating abnormally might cause injuries.
- If the unit is mistakenly dropped or strikes another object, make a thorough check of the unit for cracks, breakage or deformation, etc.  
Injuries might occur if the unit has cracks, breakage or deformation.
- When working at elevated locations, clear the area of other people and aware of conditions below you.

28. Always charge the battery at a temperature of 0°C–40°C. A temperature of less than 0°C will result in over charging which is dangerous. The battery cannot be charged at a temperature higher than 40°C.  
The most suitable temperature for charging is that of 20°C–25°C.
29. Do not use the charger continuously.  
When one charging is completed, leave the charger for about 15 minutes before the next charging of battery.
30. Do not allow foreign matter to enter the hole for connecting the rechargeable battery.
31. Never disassemble the rechargeable battery and charger.
32. Never short-circuit the rechargeable battery. Shortcircuiting the battery will cause a great electric current and overheat. It results in burn or damage to the battery.
33. Do not dispose of the battery in fire. If the battery is burnt, it may explode.
34. Bring the battery to the shop from which it was purchased as soon as the post-charging battery life becomes too short for practical use. Do not dispose of the exhausted battery.
35. Do not insert object into the air ventilation slots of the charger. Inserting metal objects or inflammables into the charger air ventilation slots will result in electrical shock hazard or damaged charger.
36. When using this unit continuously, the unit may overheat, leading to damage in the motor and switch. Therefore, whenever the housing becomes hot, give the tool a break for a while.
37. Make sure that the battery is installed firmly. If it is at all loose it could come off and cause an accident.
38. Do not use the product if the tool or the battery terminals (battery mount) are deformed.  
Installing the battery could cause a short circuit that could result in smoke emission or ignition.
39. Keep the tool's terminals (battery mount) free of swarf and dust.
  - Prior to use, make sure that swarf and dust have not collected in the area of the terminals.
  - During use, try to avoid swarf or dust on the tool from falling on the battery.
  - When suspending operation or after use, do not leave the tool in an area where it may be exposed to falling swarf or dust.  
Doing so could cause a short circuit that could result in smoke emission or ignition.
1. Make sure that swarf and dust do not collect on the battery.
  - During work make sure that swarf and dust do not fall on the battery.
  - Make sure that any swarf and dust falling on the power tool during work do not collect on the battery.
  - Do not store an unused battery in a location exposed to swarf and dust.
  - Before storing a battery, remove any swarf and dust that may adhere to it and do not store it together with metal parts (screws, nails, etc.).
2. Do not pierce battery with a sharp object such as a nail, strike with a hammer, step on, throw or subject the battery to severe physical shock.
3. Do not use an apparently damaged or deformed battery.
4. Do not use the battery for a purpose other than those specified.
5. If the battery charging fails to complete even when a specified recharging time has elapsed, immediately stop further recharging.
6. Do not put or subject the battery to high temperatures or high pressure such as into a microwave oven, dryer, or high pressure container.
7. Keep away from fire immediately when leakage or foul odor are detected.
8. Do not use in a location where strong static electricity generates.
9. If there is battery leakage, foul odor, heat generated, discolored or deformed, or in any way appears abnormal during use, recharging or storage, immediately remove it from the equipment or battery charger, and stop use.
10. Do not immerse the battery or allow any fluids to flow inside. Conductive liquid ingress, such as water, can cause damage resulting in fire or explosion. Store your battery in a cool, dry place, away from combustible and flammable items. Corrosive gas atmospheres must be avoided.

#### CAUTION

1. If liquid leaking from the battery gets into your eyes, do not rub your eyes and wash them well with fresh clean water such as tap water and contact a doctor immediately.  
If left untreated, the liquid may cause eye-problems.
2. If liquid leaks onto your skin or clothes, wash well with clean water such as tap water immediately.  
There is a possibility that this can cause skin irritation.
3. If you find rust, foul odor, overheating, discolor, deformation, and/or other irregularities when using the battery for the first time, do not use and return it to your supplier or vendor.

#### WARNING

If a conductive foreign matter enters in the terminal of lithium ion battery, the battery may be shorted, causing fire. When storing the lithium ion battery, obey surely the rules of following contents.

- Do not place conductive debris, nail and wires such as iron wire and copper wire in the storage case.
- To prevent shorting from occurring, load the battery in the tool or insert securely the battery cover for storing until the ventilator is not seen.

### CAUTION ON LITHIUM-ION BATTERY

To extend the lifetime, the lithium-ion battery equips with the protection function to stop the output.

In the cases of 1 to 3 described below, when using this product, even if you are pulling the switch, the motor may stop. This is not the trouble but the result of protection function.

1. When the battery power remaining runs out, the motor stops.  
In such a case, charge it up immediately.
2. If the tool is overloaded, the motor may stop. In this case, release the switch of tool and eliminate causes of overloading. After that, you can use it again.
3. If the battery is overheated under overload work, the battery power may stop.  
In this case, stop using the battery and let the battery cool. After that, you can use it again.

Furthermore, please heed the following warning and caution.

#### WARNING

In order to prevent any battery leakage, heat generation, smoke emission, explosion and ignition beforehand, please be sure to heed the following precautions.

## REGARDING LITHIUM-ION BATTERY TRANSPORTATION

When transporting a lithium-ion battery, please observe the following precautions.

### WARNING

Notify the transporting company that a package contains a lithium-ion battery, inform the company of its power output and follow the instructions of the transportation company when arranging transport.

- Lithium-ion batteries that exceed a power output of 100 Wh are considered to be in the freight classification of Dangerous Goods and will require special application procedures.
- For transportation abroad, you must comply with international law and the rules and regulations of the destination country.
- If the BSL36B18 is installed in the power tool, the power output will exceed 100 Wh and the unit will be classified as Dangerous Goods for freight classification.

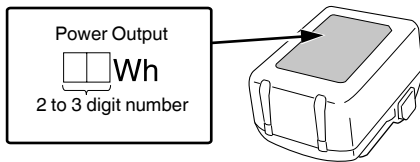

## USB DEVICE CONNECTION PRECAUTIONS (UC18YSL3)

When an unexpected problem occurs, the data in a USB device connected to this product may be corrupted or lost. Always make sure to back up any data contained in the USB device prior to use with this product.

Please be aware that our company accepts absolutely no responsibility for any data stored in a USB device that is corrupted or lost, nor for any damage that may occur to a connected device.

### WARNING

- Prior to use, check the connecting USB cable for any defect or damage.  
Using a defective or damaged USB cable can cause smoke emission or ignition.
- When the product is not being used, cover the USB port with the rubber cover.  
Buildup of dust etc. in the USB port can cause smoke emission or ignition.

### NOTE

- There may be an occasional pause during USB recharging.
- When a USB device is not being charged, remove the USB device from the charger.  
Failure to do so may not only reduce the battery life of a USB device, but may also result in unexpected accidents.
- It may not be possible to charge some USB devices, depending on the type of device.







## NAMES OF PARTS (Fig. 1 – Fig. 24)

①	Adjuster
②	Connector
③	Guard
④	Glass guard
⑤	Locking screw (diagonal cuts) (Rear)
⑥	Clamping lever (for rip fence) (Rear)
⑦	Clamping lever (for rip fence) (Front)
⑧	Undercut button
⑨	Locking screw (diagonal cuts) (Front)
⑩	Scale (diagonal cut angle)
⑪	Sub handle
⑫	Locking button
⑬	Stopper
⑭	Lock lever
⑮	Rotary button
⑯	Base
⑰	Saw blade
⑱	Hexagonal bar wrench
⑲	Battery
⑳	Nameplate
㉑	Dial
㉒	Handle
㉓	Trigger switch
㉔	Lock-off button
㉕	Motor
㉖	Cutting indicator
㉗	Rip fence
㉘	Latch
㉙	Charge indicator lamp
㉚	Read-off edge
㉛	Symbol "saw blade changing"
㉜	Saw blade fixing screw
㉝	Washer (B)
㉞	Read-off edge of guide rail "GR"
㉟	Adjusting screw (A)
㊱	Adjusting screw (B)
㊲	Marking
㊳	Guide grooves
㊴	Battery level indicator switch
㊵	Battery level indicator lamp
㊶	Dust bag
㊷	Rubber cover
㊸	USB port
㊹	USB cable
㊺	Air gun







## SYMBOLS

### WARNING

The following show symbols used for the machine. Be sure that you understand their meaning before use.

	C3606DPA: Cordless Plunge Cut Saw
	To reduce the risk of injury, user must read instruction manual.
	Always wear eye protection.
	Always wear hearing protection.
V	Rated voltage
$n_0$	No-load speed
I	Switching ON
O	Switching OFF
	Disconnect the battery
	Prohibited action

### Battery

	Lights ; The battery remaining power is over 75%.
	Lights ; The battery remaining power is 50%–75%.
	Lights ; The battery remaining power is 25%–50%.
	Lights ; The battery remaining power is less than 25%.
	Blinks ; The battery remaining power is nearly empty. Recharge the battery soonest possible.
	Blinks ; Output suspended due to high temperature. Remove the battery from the tool and allow it to fully cool down.
	Blinks ; Output suspended due to failure or malfunction. The problem may be the battery so please contact your dealer.

### NOTE

To prevent the battery power consumption caused by forgetting to turn off the LED light, the light goes off automatically in about 2 minutes.

## STANDARD ACCESSORIES

In addition to the main unit (1 unit), the package contains the accessories listed on page 21.

Standard accessories are subject to change without notice.

## APPLICATIONS

The cordless plunge cut saw is suitable for sawing wood, plastics and other similar materials. It must not be used for sawing metals, except for thin aluminium sheets (thinner than 2 mm) and aluminium-laminated wooden or composite boards.

## SPECIFICATIONS

### 1. Power tool

Model		C3606DPA	
Voltage		36 V	
No-Load Speed		2500–5200 /min	
Capacity	Cutting depth	0°	66 mm
		45°	43 mm
Blade size		165 mm (D) × 20 mm (H)	
Max. blade angle		-1°–46°	
Battery available for this tool*		Multi volt battery	
Weight		5.4 kg (BSL36B18)	

\* Existing batteries (BSL3660/3620/3626, BSL18xx series, etc.) cannot be used with this tool. When using the AC/DC adapter, the performance of the brake function varies by power source.

### NOTE

Due to HiKOKI's continuing program of research and development, the specifications herein are subject to change without prior notice.

### Electronic control

- Soft-start
- Overload protection
 

This protection feature cuts off the power to the motor in the event of overloading of motor or a conspicuous reduction in rotational speed during operation. When the overload protection feature has been activated, the motor may stop. In this case, release the tool switch and eliminate causes of overloading. After that you can use it again.
- Overheat protection
 

This protection feature cuts off the power to the motor and stops the power tool in the event of overheating of motor during operation. When the overheat protection feature has been activated, the motor may stop. In this case, release the tool switch and cool it down in a few minutes. After that you can use it again.
- Brake function
 

Brake activates when the trigger is off. The performance of the brake function varies by power source.

2. Battery (sold separately)

Model	BSL36B18
Voltage	36 V / 18 V (Automatic Switching*)
Battery capacity	4.0 Ah / 8.0 Ah (Automatic Switching*)
Available cordless products**	Multi volt series, 18 V product
Available charger	Sliding charger for lithium ion batteries

\* The tool itself will automatically switch over.

\*\* Please see our general catalogue for details.

## CHARGING

Before using the power tool, charge the battery as follows.

**1. Connect the charger's power cord to the receptacle.**  
When connecting the plug of the charger to a receptacle, the charge indicator lamp will blink in red (At 1- second intervals).

**2. Insert the battery into the charger.**  
Firmly insert the battery into the charger as shown in **Fig. 8** (on page 4).

**3. Charging**  
When inserting a battery in the charger, the charge indicator lamp will blink in blue.  
When the battery becomes fully recharged, the charge indicator lamp will light up in green. (See **Table 1**)

(1) Charge indicator lamp indication  
The indications of the charge indicator lamp will be as shown in **Table 1**, according to the condition of the charger or the rechargeable battery.

**Table 1**

Indications of the charge indicator lamp				
Charge indicator lamp (RED / BLUE / GREEN / PURPLE)	Before charging	Blinks (RED)	Lights for 0.5 seconds. Does not light for 0.5 seconds. (off for 0.5 seconds)	Plugged into power source
	While charging	Blinks (BLUE)	Lights for 0.5 seconds. Does not light for 1 second. (off for 1 second)	Battery capacity at less than 50%
		Blinks (BLUE)	Lights for 1 second. Does not light for 0.5 seconds. (off for 0.5 seconds)	Battery capacity at less than 80%
		Lights (BLUE)	Lights continuously	Battery capacity at more than 80%
	Charging complete	Lights (GREEN)	Lights continuously (Continuous buzzer sound: about 6 seconds)	
	Overheat standby	Blinks (RED)	Lights for 0.3 seconds. Does not light for 0.3 seconds. (off for 0.3 seconds)	Battery overheated. Unable to charge. (Charging will commence when battery cools)
	Charging impossible	Flickers (PURPLE)	Lights for 0.1 seconds. Does not light for 0.1 seconds. (off for 0.1 seconds) (Intermittent buzzer sound: about 2 seconds)	Malfunction in the battery or the charger

- (2) Regarding the temperatures and charging time of the rechargeable battery  
The temperatures and charging time will become as shown in **Table 2**.

**Table 2**

Charger		UC18YSL3					
Battery	Type of battery	Li-ion					
	Temperatures at which the battery can be recharged	0°C–50°C					
	Charging voltage	V	14.4		18		
	Charging time, approx. (At 20°C)	min	BSL14xx series		BSL18xx series		Multi volt series
			(4 cells)	(8 cells)	(5 cells)	(10 cells)	(10 cells)
		BSL1415S : 15 BSL1415 : 15 BSL1415X : 15 BSL1420 : 20 BSL1425 : 25 BSL1430C : 30	BSL1430 : 20 BSL1440 : 26 BSL1450 : 32 BSL1460 : 38	BSL1815S : 15 BSL1815 : 15 BSL1815X : 15 BSL1820 : 20 BSL1820M : 20 BSL1825 : 25 BSL1830C : 30 BSL1840M : 40 BSL1850C : 32	BSL1830 : 20 BSL1840 : 26 BSL1850 : 32 BSL1850MA : 32 BSL1860 : 38	BSL36A18 : 32 BSL36B18 : 52	
USB	Charging voltage	V	5				
	Charging current	A	2				

**NOTE**

The recharging time may vary according to the ambient temperature and power source voltage.

4. **Disconnect the charger's power cord from the receptacle.**

5. **Hold the charger firmly and pull out the battery.**

**NOTE**

Be sure to pull out the battery from the charger after use, and then keep it.

**Regarding electric discharge in case of new batteries, etc.**

As the internal chemical substance of new batteries and batteries that have not been used for an extended period is not activated, the electric discharge might be low when using them the first and second time. This is a temporary phenomenon, and normal time required for recharging will be restored by recharging the batteries 2–3 times.

**How to make the batteries perform longer.**

- (1) Recharge the batteries before they become completely exhausted.

When you feel that the power of the tool becomes weaker, stop using the tool and recharge its battery. If you continue to use the tool and exhaust the electric current, the battery may be damaged and its life will become shorter.

- (2) Avoid recharging at high temperatures.

A rechargeable battery will be hot immediately after use. If such a battery is recharged immediately after use, its internal chemical substance will deteriorate, and the battery life will be shortened. Leave the battery and recharge it after it has cooled for a while.

**CAUTION**

- If the battery is charged while it is heated because it has been left for a long time in a location subject to direct sunlight or because the battery has just been used, the charge indicator lamp of the charger lights for 0.3 seconds, does not light for 0.3 seconds (off for 0.3 seconds). In such a case, first let the battery cool, then start charging.

- When the charge indicator lamp flickers (at 0.2-second intervals), check for and take out any foreign objects in the charger's battery connector. If there are no foreign objects, it is probable that the battery or charger is malfunctioning. Take it to your authorized Service Center.

**MOUNTING AND OPERATION**

Action	Figure	Page
Removing and inserting the battery	7	4
Charging	8	4
Remaining battery indicator	19	6
Charging a USB device from a electrical outlet	20-a	6
Charging a USB device and battery from a electrical outlet	20-b	6
How to recharge USB device	21	6
When charging of USB device is completed	22	6
Selecting accessories	—	22

**PRIOR TO OPERATION**

**WARNING**

To avoid serious accident, ensure the switch is in the OFF position, and pull out the battery.

1. **Check the work area environment**

Check the work area to make sure that it is clear of debris and clutter.

Clear the area of unnecessary personnel. Ensure that lighting and ventilation is adequate.

## 2. Changing saw blades

### WARNING

If the saw blade fixing screw is worked using other tools than the provided hexagonal bar wrench, excessive tightening and insufficient tightening may take place, resulting in injury.

- (1) Thoroughly remove any sawdust which has accumulated on the spindle, screw and washers.
- (2) Press the locking button and move.
- (3) Move in such a way that the read-off edge is pointed to the symbol "saw blade changing". (Fig. 9-a)
- (4) Release the locking button again.
- (5) Turn the lock lever clockwise up to the stop. (Fig. 9-b)
- (6) Push the lock-off button forwards and lower the motor section a little. Release the lock-off button again.
- (7) Push the motor section down until it locks in place at the stop.
- (8) Turn the saw spindle slowly with the hexagonal bar wrench in the saw blade fixing screw until the lock catches.
- (9) Unscrew the saw blade fixing screw in a clockwise direction and remove the washer (B). Remove the saw blade. (Fig. 10)

### CAUTION

Ensure that the washer (A) (the washer inside the saw blade) is inserted in the right way: The washer (A) has 2 sides, diameter 20 mm and 5/8" (16 mm). Ensure a precise fit of saw blade mounting hole to the washer (A). Incorrectly installed saw blades do not run smoothly and lead to loss of control.

- (10) Insert a new saw blade, Make sure the direction of rotation is correct. The direction of rotation is indicated by arrows on the saw blade and guard.  
The contact areas between the washer (A), the saw blade, the washer (B) and the saw blade fixing screw must be clean.
- (11) Put on the washer (B). Ensure that the washer (B) is inserted the correct way round.
- (12) Tighten the saw blade fixing screw using a hexagonal bar wrench (max. 5 Nm).

### CAUTION

- Use only sharp, undamaged saw blades. Do not use saw blades that are cracked or that have changed their shape.
  - Do not use any saw blades made from high-alloy high-speed steel (HSS).
  - Do not use any saw blades which do not conform to the specified rating.  
Use only saw blades with a diameter according to the markings on the saw.
  - The saw blade must be suitable for the no-load speed.
  - Use a saw blade that is suitable for the material being sawn.
  - Use only genuine HIKOKI saw blades. Saw blades intended for cutting wood or similar materials have to conform to EN 847-1.
- (13) Turn the lock lever anti-clockwise up to the stop while holding the handle with one hand. The motor section swings upwards.

### CAUTION

Never touch the saw blade immediately after use. The metal is hot and can easily burn your skin.

### 3. Check for proper operation of the brake

This power tool features an electric brake that functions when the switch is released. Before using the power tool, ensure that the electric brake functions properly. If it does not, bring the tool to a HIKOKI AUTHORIZED SERVICE CENTER.

## ADJUSTING THE SAW PRIOR TO USE

### WARNING

To avoid serious accidents, ensure the switch is in OFF position, and pull out the battery.

#### 1. Setting cutting depth

It is advisable to set the depth of cut in such a way that no more than half of each tooth on the saw blade juts out under the workpiece. (Fig. 11-a)

<Adjustment in mm steps>

Press the locking button and move. Read off the set cutting depth at the read-off edge.

(When the guide rail "GR" is used, read off at the "GR" read-off edge.)

Release the locking button again. (Fig. 11-b)

<Precise adjustment (for extremely precise cutting depth adjustment)>

The cutting depth can be set extremely precisely by turning the adjuster.

Determine the exact cutting depth by measuring the projecting saw blade or check the result by a trial cut.

#### 2. Slanting saw blade for diagonal cuts (Fig. 12)

Loosen the two locking screws to make the setting. Tilt the motor section against the base. Read the angle which has been set from the scale. Retighten both locking screws.

For a diagonal cut angle smaller 0° or greater 45° (undercut):

Press the undercut button in and then slant.

(During the next adjustment the undercut function is automatically deactivated.)

When cutting at an angle, adjust the position of the glass guard so that it does not hit the workpiece being cut.

### WARNING

If the locking screw is loose, injury can result. Tighten it securely after adjustment.

#### 3. Correcting the saw blade angle

The saw blade angle has been adjusted at the factory. (Fig. 13)

If necessary, the saw blade angle can be adjusted for 0° and for 45°. Turn the adjusting screw (B) (for 0°) or adjusting screw (A) (for 45°).

#### 4. Sawing with a rip fence (sold separately) (Fig. 14)

For cuts parallel to a straight edge. The rip fence can be inserted from either side into the support provided for it. The cut width can be read off at the mark. Fix using both clamping levers. It is best to calculate the exact cut width by making a test cut.

#### 5. Sawing with a guide rail (sold separately) (Fig. 15)

For dead straight, tear-free cutting edges with millimeter precision. The anti-slip coating keeps the surface safe and protects the workpiece against scratches. See Accessories section. The rotary button is used for setting a clearance-free fit.

There are two guide grooves to place the machines on guide tracks from different manufacturers.

#### 6. Setting extraction connector / dust ejection

The connector can be rotated to the desired position to extract or eject sawdust. To do this, push the connector in up to the stop, turn and pull out again. The connector can thus be locked in 7 increments so that it cannot turn.

<Sawdust extraction>

To extract the sawdust, connect a suitable extraction unit with suction hose to the connector.

<Dust bag>

Remove the connector (push the connector in up to the stop. Turn it so that it is facing upwards. Remove and set to one side).

Attach the dust bag. (Fig. 16)



## 7. Adjusting the glass guard

Move the glass guard: top position for diagonal cuts, central position for 0° cuts, bottom position when a guide rail is used.

## OPERATION

### WARNING

- Pull out the battery after completing operation.
- Never touch the moving parts.
- Do not fix and secure the lock-off button. Besides, keep your finger off the trigger switch when the power tool is being carried around. Otherwise, the main body switch can be inadvertently turned ON, resulting in unexpected accidents.
- Do not use any abrasive wheels.
- Use only blade diameter specified on the product nameplate.
- Should the saw blade be stopped or make an abnormal noise during operation, turn off the switch immediately.

### CAUTION

- To extend the lifetime, the lithium-ion battery equips with the protection function to stop the output. Therefore, if the tool is overloaded, the motor may stop. However, this is not the trouble but the result of protection function. In this case, release the switch of tool and eliminate the causes of overloading.
- Take care not to lock the motor. If the motor is locked, immediately turn the power off. If the motor is locked for a while, the motor or battery may be burnt.
- Before use, check to see if the lock-off button moves smoothly.

#### 1. Check if saw blade is tightened

While the saw blade is tightened securely for immediate use when it is assembled at the factory, be sure to check it out again for caution's sake. A saw blade fixing screw can be tightened when it is turned clockwise.

Use the provided hexagonal bar wrench to check it out. For further details, refer to the item of PRIOR TO OPERATION.

#### 2. Switching on and off

When the lock-off button is pushed forwards, the motor section can be moved downwards. The saw blade then emerges from the guard.

<Switching on>

Push the lock-off button forwards and hold, then actuate the trigger switch.

<Switching off>

Release the trigger switch.

#### 3. Rotational speed preselection

Select the speed at the dial. For recommended speeds, see Fig. 18.

#### 4. Working Directions

### WARNING

- Do not switch the machine on or off while the saw blade is touching the workpiece.
- Let the saw blade reach its full speed before making a cut.
- When sawing, never remove the machine from the material with the saw blade turning. Allow the saw blade to come to a standstill.
- If the saw blade blocks, turn the machine off immediately.
- Do not set the machine down until the saw blade has come to a standstill.

<Plunge cuts>

The motor section is in the upper position, the saw blade does not project from the base. Hold the machine tightly with both hands and place with the base onto the workpiece. Switch on the machine. Lower the motor section slowly to the set cutting depth and then move slowly in cutting direction.

<Sawing along a straight line>

The cutting indicator is used here. The left edge (marked red) indicates the direction of the cut if the saw blade is held vertically. The right edge indicates the direction of the cut if the saw blade is held at 45°. (Fig. 17)

<Sawing along a guard rail secured on the workpiece>

In order to achieve an exact cutting edge, you can attach a guard rail to the workpiece and then guide the hand-held circular saw by means of the base along this guard rail.

### CAUTION

- To avoid abnormal heating of the blade tip or damage to the saw blade, do not twist or apply excessive force to the saw blade when cutting. Let the blade move forward smoothly.
- In the situation where the circular saw is continuously operated while replacing the battery with stocked spare batteries one after another, the motor tends to overheat. Therefore, whenever the housing becomes hot, give the saw a break for a while.
- Avoid cutting operation in a state where the base bottom is afloat from the material being cut. Otherwise, the motor can get locked.

## MAINTENANCE AND INSPECTION

### WARNING

Be sure to turned off the switch and remove the battery before maintenance and inspection.

#### 1. Inspecting the saw blade

Since use of as dull saw blade will degrade efficiency and cause possible motor malfunction, sharpen or replace the saw blade as soon as abrasion is noted.

#### 2. Inspecting the mounting screws

Regularly inspect all mounting screws and ensure that they are properly tightened. Should any of the screws be loose, retighten them immediately. Failure to do so could result in serious hazard.

#### 3. Motor unit maintenance

The motor winding is an important part of this tool. Avoid damaging and be careful to avoid contact with cleaning oil or water.

After 50 hours of use, clean the motor by blowing into the ventilation holes of the motor housing with dry air from an air gun or other tool (Fig. 23).

Dust or particle accumulation in the motor can result in damage.

### WARNING

To prevent dust inhalation or eye irritation, wear protective safety goggles and a dust mask when using an air gun or other tool to clean the lower guard, ventilation holes or other parts of the product.

#### 4. Cleaning the inside of the guard

Regularly check and clean to make sure that sawdust and other residue do not collect inside of the saw cover. Always remove the saw blade when checking and cleaning (Fig. 24).

#### 5. Inspection of terminals (tool and battery)

Check to make sure that swarf and dust have not collected on the terminals.

On occasion check prior, during and after operation.

### CAUTION

Remove any swarf or dust which may have collected on the terminals.

Failure to do so may result in malfunction.

#### 6. Cleaning on the outside

When the power tool is stained, wipe with a soft dry cloth or a cloth moistened with soapy water. Do not use chloric solvents, gasoline or paint thinner, for they melt plastics.

## 7. Storage

Store the power tool and the battery in a place in which the temperature is less than 40°C and out of reach of children.

### NOTE

Storing lithium-ion batteries.

Make sure the lithium-ion batteries have been fully charged before storing them.

Prolonged storage (3 months or more) of batteries with a low charge may result in performance deterioration, significantly reducing battery usage time or rendering the batteries incapable of holding a charge.

However, significantly reduced battery usage time may be recovered by repeatedly charging and using the batteries two to five times.

If the battery usage time is extremely short despite repeated charging and use, consider the batteries dead and purchase new batteries.

### CAUTION

In the operation and maintenance of power tools, the safety regulations and standards prescribed in each country must be observed.

#### **Important notice on the batteries for the HiKOKI cordless power tools**

Please always use one of our designated genuine batteries. We cannot guarantee the safety and performance of our cordless power tool when used with batteries other than these designated by us, or when the battery is disassembled and modified (such as disassembly and replacement of cells or other internal parts).

---

### NOTE

Due to HiKOKI's continuing program of research and development, the specifications herein are subject to change without prior notice.

---

## TROUBLESHOOTING

Use the inspections in the table below if the tool does not operate normally. If this does not remedy the problem, consult your dealer or the HIKOKI Authorized Service Center.





### 1. Power tool

Symptom	Possible cause	Remedy
Tool doesn't run	No remaining battery power	Charge the battery.
	Battery isn't fully installed.	Push the battery in until you hear a click.
Tool suddenly stopped	Tool was overburdened	Get rid of the problem causing the overburden.
	Overload protection is in operation.	
	The battery is overheated.	Let the battery cool down.
Cannot be inclined	The incline lever (front) and incline wing nut (rear) are not loosened.	Try inclining after loosening the incline lever (front) and incline wing nut (rear). Tighten the loosened parts after making the necessary adjustments.
Doesn't cut well	The saw blade is worn or missing teeth.	Replace with a new saw blade.
	The saw blade fixing screw is loose.	Firmly tighten the saw blade fixing screw.
	The saw blade is installed backwards.	Install the saw blade in the proper direction.
Switch can't be pulled	The lock-off button is not pushed in enough.	Push the lock-off button in all the way.
Sawdust discharge is poor	Sawdust has accumulated in the saw cover.	Remove the sawdust inside the saw cover.
Battery cannot be installed	Attempting to install a battery other than that specified for the tool.	Please install a multi volt type battery.

### 2. Charger

Symptom	Possible cause	Remedy
The charge indicator lamp is rapidly flickers purple, and battery charging doesn't begin.	The battery is not inserted all the way.	Insert the battery firmly.
	There is foreign matter in the battery terminal or where the battery is attached.	Remove the foreign matter.
The charge indicator lamp blinks red, and battery charging doesn't begin.	The battery is not inserted all the way.	Insert the battery firmly.
	The battery is overheated.	If left alone, the battery will automatically begin charging if its temperature decreases, but this may reduce battery life. It is recommended that the battery be cooled in a well-ventilated location away from direct sunlight before charging it.
Battery usage time is short even though the battery is fully charged.	The battery's life is depleted.	Replace the battery with a new one.
The battery takes a long time to charge.	The temperature of the battery, the charger, or the surrounding environment is extremely low.	Charge the battery indoors or in another warmer environment.
	The charger's vents are blocked, causing its internal components to overheat.	Avoid blocking the vents.
	The cooling fan is not running.	Contact a HIKOKI Authorized Service Center for repairs.
The USB power lamp has switched off and the USB device has stopped charging.	The battery's capacity has become low.	Replace the battery with one that has capacity remaining.
		Plug the charger's power plug into an electric socket.
USB power lamp does not switch off even though the USB device has finished charging.	The USB power lamp lights up green to indicate that USB charging is possible.	This is not a malfunction.

Symptom	Possible cause	Remedy
It is unclear what the charging status of a USB device is, or whether its charging is complete.	The USB power lamp does not switch off even when charging is complete.	Examine the USB device that is charging to confirm its charging status.
Charging of a USB device pauses midway.	The charger was plugged into an electrical socket while the USB device was being charged using the battery as the power source.	This is not a malfunction. The charger pauses USB charging for about 5 seconds when it is differentiating between power sources.
	A battery was inserted into the charger while the USB device was being charged using a power socket as the power source.	
Charging of the USB device pauses midway when the battery and the USB device are being charged at the same time.	The battery has become fully charged.	This is not a malfunction. The charger pauses USB charging for about 5 seconds while it checks whether the battery has successfully completed charging.
Charging of the USB device doesn't start when the battery and the USB device are being charged at the same time.	The remaining battery capacity is extremely low.	This is not a malfunction. When the battery capacity reaches a certain level, USB charging automatically begins.

				
C3606DPA (NN)	1	1	1	1

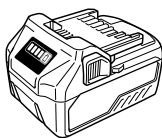

Multi Volt (Li-ion)

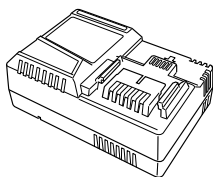

UC18YSL3 (14,4V-18V)



329897

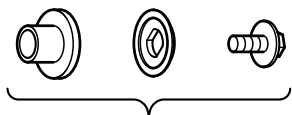

379630

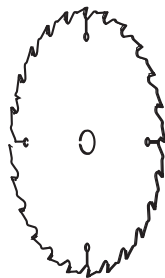

Blade

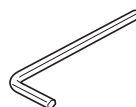

379629

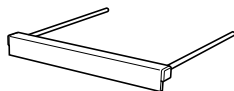

4100082

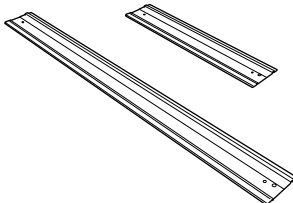

GR800: 4100071  
GR1600: 4100072



4100083

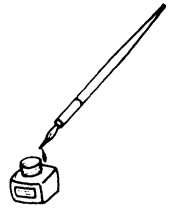

# Koki Holdings Co., Ltd.

Shinagawa Intercity Tower A, 15-1, Konan 2-chome,  
Minato-ku, Tokyo, Japan