

HiKOKI

Finish Nailer Model NT 65M2

Handling instructions

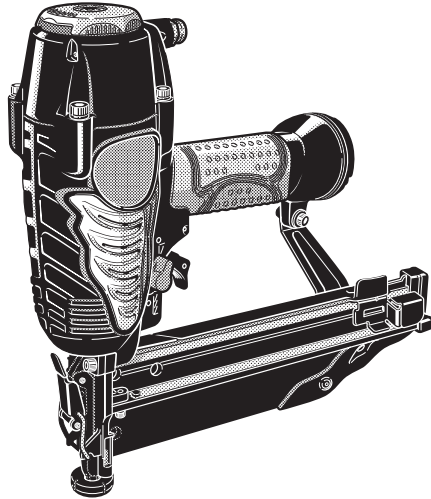

Note:

Before using this Pneumatic Power Tool, carefully read through these HANDLING INSTRUCTIONS to ensure efficient, safe operation. It is recommended that these INSTRUCTIONS be kept readily available as an important reference when using this power tool.

GENERAL OPERATIONAL PRECAUTIONS

- 1. Operate the power tool safely for correct uses.**
Do not use the power tool for uses other than those specified in this instructions.
- 2. For safe operation handle the power tool correctly.**
Please follow the instructions given in this instruction manual and correctly handle this tool so as to ensure safe operation. Never let the tool be used by children or people who do not know enough to be able to handle it correctly, or let it be used by people who cannot operate it correctly.
- 3. Confirm the safety of the workshop.**
Keep unauthorized people away from the workshop. Especially children should be kept away.
- 4. The right parts in the right places.**
Do not remove any of the covers or screws. Keep them in place as they have their functions. Moreover, because it would be dangerous, never make modifications to the tool or use it after making modifications.
- 5. Check the tool before using it.**
Before using the tool, always check that no parts of it are broken, that all screws are completely tight, and that no parts are missing or rusty.
- 6. Excessive work could cause accidents.**
Do not make tools and accessories work beyond their abilities. Excessive work not only damages the power tool but also is dangerous in itself.
- 7. Stop operation immediately if abnormalities are noticed.**
Stop operation if you notice abnormalities, or if the power tool does not work properly; have the power tool inspected and serviced.
- 8. Look after the power tool carefully.**
If you drop or knock the power tool against things, the outer frame may be deformed and cracks or other kinds of damage may occur, so please handle it with sufficient care. Also, do not scratch or engrave signs on the power tool. Owing to high pressure air inside the tool, cracks in the surface are dangerous.
Never use the power tool if a crack develops or if air is escaping from a crack.
- 9. Take good care for a long life.**
Always take good care of the power tool and keep it clean.
- 10. Inspection at regular intervals is essential for safety.**
Inspect the power tool at regular intervals so that the power tool can be operated safely and efficiently at all times.
- 11. Consult an authorized service center if repair or parts replacement is necessary.**
Ensure that the power tool is serviced by authorized service center only, and that only genuine replacement parts are used.
- 12. Keep the power tool in a proper place.**
When not in use, the power tool should be kept in a dry place out of the reach of children. Put into the body about 2cc oil through the hose joint to protect the tool from rust.
- 13. The exploded assembly drawing on this handling instructions should be used only for authorized service center.**

PRECAUTIONS ON USING NAILER

- 1. Safe operation through correct usage**
This tool was designed for driving nails into wood and similar materials. Use it for its intended purpose only.
- 2. Make sure air pressure is within the rated range of air pressure.**
Please make sure that the air pressure is within a range of 4.9 bar – 8.3 bar, and that the air which is used is clean and dry. If the air pressure is greater than 8.3 bar, the life of the power tool will be shortened and dangerous conditions could develop. Tools shall not be connected to pressure which potentially exceeds 14 bar.
- 3. Never operate the equipment with high-pressure gases other than compressed air.**
Never use carbon dioxide, oxygen or another gas from pressurized containers under any circumstances.
- 4. Be careful of ignition and explosions.**
Since sparks may fly during nailing, it is dangerous to use this tool near lacquer, paint, benzine, thinner, gasoline, gas, adhesives and similar inflammable substances as they may ignite or explode. Under no circumstances should this tool therefore be used in the vicinity of such inflammable material.
- 5. Always wear eye protection (protective goggles).**
When operating the power tool, always wear eye protection, and ensure that surrounding people wear eye protection too.
The possibility of fragments of the nails that were not properly hit entering the eye is a threat to sight. Eye protection can be bought at any hardware store. Always wear eye protection while operating this tool. Use either eye protection or a wide vision mask over prescription glasses. Employers should always enforce the use of eye protection equipment.
- 6. Protect your ears and head.**
When engaged in nailing work please wear ear mufflers and head protection. Also, depending on condition, ensure that surrounding people also wear ear mufflers and head protection.
- 7. Pay attention to those working close to you.**
It would be very dangerous if nails that were not properly driven in should hit other people. Therefore, always pay attention to the safety of the people around you when using this tool. Always make sure that nobody's body, hands or feet are close to the nail outlet.
- 8. Never point the nail outlet towards people.**
Always assume the tool contains fasteners. If the nail outlet is pointed towards people, serious accidents may be caused if you mistakenly discharge the tool. When connecting and disconnecting the hose, during nail loading or similar operations, be sure the nail outlet is not pointed towards anyone (including yourself). Even when no nails are loaded at all, it is dangerous to discharge the tool while pointing it at someone, so never attempt to do so. No horseplay. Respect the tool as a working implement.
- 9. Before using the power tool, check the push lever.**
Before using the power tool make sure to check that the push lever and valve operate properly. Without nails loaded into the power tool, connect the hose and check the following. If the sound of operation occurs this indicates a fault, so in

- such a case do not use the power tool until it has been inspected and repaired.
- If merely pulling the trigger causes operating sound of drive bit movement occur, the power tool is faulty.
 - If merely pushing the push lever against the material to be nailed causes the sound of drive bit movement to occur, the power tool is faulty. Furthermore, with regard to the push lever, please note that it must never be modified or removed.
10. **Use specified nails only.**
Never use nails other than those specified and described in these instructions.
 11. **Be careful when connecting the hose.**
When connecting the hose and loading nails in order not to fire the tool by mistake, make sure of the followings.
 - Do not touch the trigger.
 - Do not allow the firing head to contact with any surface.
 - Keep the firing head down.
Strictly observe the above instructions, and always make sure that no part of the body, hands or legs is ever in front of the nail outlet.
 12. **Do not carelessly place your finger on the trigger.**
Do not place your finger on the trigger except when actually nailing. If you carry this tool or hand it to someone while having your finger on the trigger, you may inadvertently discharge a nail and thus cause an accident.
 13. **Press the nail outlet firmly against the material to be nailed.**
When driving in nails, press the nail outlet firmly against the material to be nailed. If the outlet is not applied properly, the nails may rebound.
 14. **Keep hands and feet away from the firing head when using.**
It is very dangerous for a nail to hit the hands or feet by mistake.
 15. **Beware of the tool's kickback**
Do not approach the top of the tool with your head etc. during operation. This is dangerous because the tool may recoil violently if the nail currently being driven in comes into contact with a previous nail or a knot in the wood.
 16. **Take care when nailing thin boards or the corners of wood.**
When nailing thin boards, the nails may pass right through, as may also be the case when nailing the corners of wood due to deviation of the nails. In such cases, always make sure that there is no one (and nobody's hands or feet; etc.) behind the thin board or next to the wood you are going to nail.
 17. **Simultaneous nailing on both sides of the same wall is dangerous**
Under no circumstances should nailing be performed on both sides of a wall at the same time. This would be very dangerous since the nails might pass through the wall and thus cause injuries.
 18. **Do not use the power tool on scaffoldings, ladders.**
The power tool shall not be used for specific application for example:
 - when changing one driving location to another involves the use of scaffoldings, stairs, ladders or ladder alike constructions, e.g. roof laths,
 - closing boxes or crates,
 - fitting transportation safety systems e.g. on vehicles and wagons
 19. **Do not disconnect the hose with your finger on the trigger.**
If you disconnect the hose with your finger on the trigger, the next time the hose is connected, there is a danger that the power tool will fire a nail spontaneously, or operate incorrectly.
 20. **Disconnect the hose and take out any nails left in the magazine after use.**
Disconnect tool from air before doing tool maintenance, cleaning a jammed fastener, leaving work area, moving tool to another location, or after use. It is very dangerous for a nail to be fired by mistake.
 21. **When removing a nail which has become stuck, make sure to first of all disconnect the hose and release compressed air.**
When removing a nail which has become stuck in the nail outlet, first of all make sure to disconnect the hose and release compressed air inside the power tool.
Accidental firing of the nail could be very dangerous.
 22. **A female plug (air socket) should not be used in the body.**
If a female plug is installed in the body, the compressed air sometimes can not be drawn when the hose is disconnected so avoid this.
The tool and air supply hose must have a hose coupling such that all pressure is removed from the tool when the coupling joint is disconnected.
 23. **When attaching and detaching the nose cap, disconnect the hose.**
When attaching the accessory nose cap to the tip of the push lever and when detaching it, make sure to disconnect the hose beforehand. It is very dangerous for a nail to be fired by mistake.

NAME OF PARTS

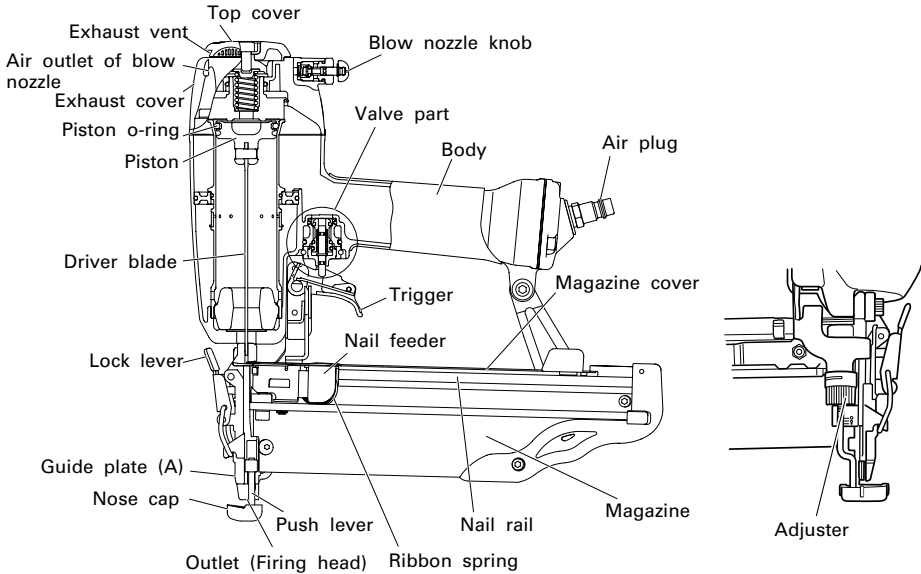

Fig. 1

SPECIFICATIONS

Type of power	Piston reciprocating
Air pressure (Gauge)	4.9 – 8.3 bar
Applicable nails	ref. Fig.
Numbers of loadable nails	100 nails (2 strips)
Size	295 mm (L) × 285 mm (H) × 71 mm (W)
Weight	1.7 kg (3.7 lbs)
Nail-feeding method	Piston reciprocation
Hose (inside diam.)	6 mm (1/4")

NAIL SELECTION

Choose a suitable nail from Fig. Nails which are not shown in Fig. can not be driven with this tool.

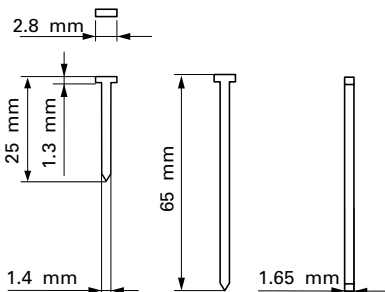

STANDARD ACCESSORIES

- (1) Eye protector 1
- (2) Nose cap (mounted on tool) 1
- (3) Case 1

APPLICATIONS

- Nailing as a finishing process for areas around the doors, windows as well as edgings.
- Securing the bottom of drawers. Making various cases and cabinets.

PREPARATION PRIOR TO OPERATION

1. Prepare the hose

Be sure to use the hose provided with minimum 6 mm inside diameter.

NOTE

The air supply hoses must have a minimum working pressure rating of 12.8 bar or 150 percent of the maximum pressure produced in the air supply system, whichever is higher.

2. Check on safety

CAUTIONS

- Unauthorized persons (including children) must be kept away from the equipment.
- Wear eye protector.
- Check the retaining screws which fix the exhaust cover, etc. for tightness.
Check the nailer for air leaks and defective or rusty parts.
- Check whether or not the push lever works correctly. Also check whether or not any dirt has adhered to the moving parts of the push lever.
- Recheck on operational safety.

BEFORE USE

1. Check the air pressure

CAUTION

The air pressure must be constantly maintained at 4.9 – 8.3 bar.

Adjust the air pressure between 4.9 to 8.3 bar according to the diameters and length of nails and hardness of the wood being nailed. Pay special attention to the output pressure, capacity, and piping on the air compressor, so that air pressure does not exceed the specified limit. Note that excessive pressure may affect overall performance, service life, and safety.

2. Lubrication

- (1) Prior to operating this nailer, be sure to provide an air set between the air compressor and this device. Lubrication through the air set offers smooth operation, extended service life, and anticorrosion. Adjust the oiler so that a single drop of oil is supplied at intervals of 5 to 10 nailing cycles.
- (2) It is recommended using the recommended oil (SHELL TONNA). Other applicable oils are listed. Never mix two or more types of different oils.

3. Load nails

- (1) Pull the nail feeder until the concave portion of the magazine cover clicks. (See Fig. 2)

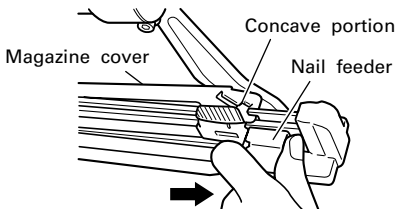

Fig. 2

- (2) ① Insert nail strips one by one from above the magazine.
② Slide nails forward in the magazine.

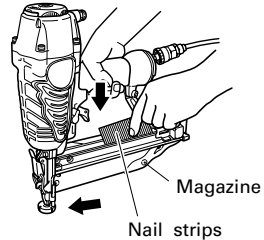

Fig. 3

- (3) ① While holding the nail feeder adjust the magazine cover in place.
② Slide the nail feeder slowly forward until it contacts nails.

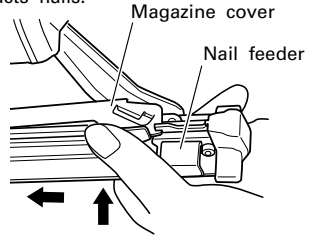

Fig. 4

NOTE

- Use nails at least 5 nails remaining.
- Slide the nail feeder SLOWLY forward. If the nail feeder is released roughly, it may be stuck between the magazine and nails, which makes mis-feeding trouble.

CAUTION

- When loading nails into Nailer,
(1) do not pull trigger;
(2) do not depress push lever; and
(3) keep Nailer pointed downward.

HOW TO USE THE NAILER

CAUTIONS

- Never use the head or body of this device as a hammer.
- Take precautions to ensure the safety of persons in the vicinity during operation.

1. Nailing procedures

This HIKOKI nailer is equipped with a nailer operation switching device.

Use SINGLE ACTUATION MECHANISM or CONTACT ACTUATION MECHANISM in accordance with the work to be performed.

(1) Intermittent nailing

Set the switching device to the upward position (to set to SINGLE ACTUATION MECHANISM) (See Fig. 5).

Depress the nail outlet onto the desired point; then pull the trigger to drive a nail in a single shot (See Fig. 6).

After nailing once, nailing will not be possible again until the trigger is released and pressed again.

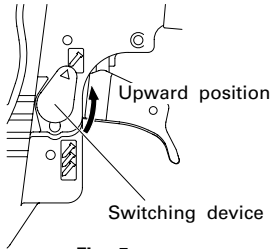

Fig. 5

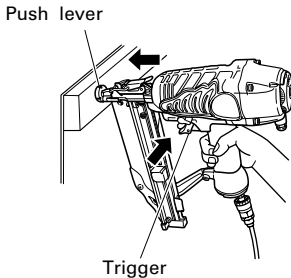

Fig. 6

CAUTION

If you do not pull the trigger quickly and crisply while in the single shot mode, the nailer will bounce and shoot several nails instead of just one. To avoid this, be sure to pull the trigger quickly and crisply.

(2) Push lever

When depressing the nail outlet, be sure to fully lift the push lever (See Fig. 6) to release the safety lock. Thus, nails cannot be driven without releasing the safety lock even though the trigger is pulled.

(3) Continuous nailing

Set the switching device to the downward position (to set to CONTACT ACTUATION MECHANISM) (See Fig. 7).

First, pull the trigger. Then depress the device onto the desired position to automatically drive nails (See Fig. 8).

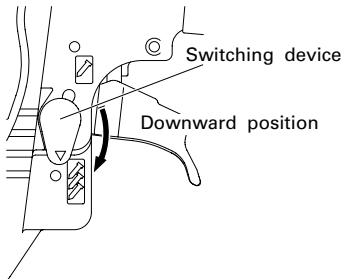

Fig. 7

Previously pull the trigger

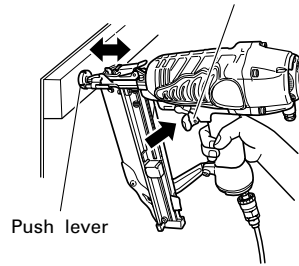

Fig. 8

CAUTION

- Exercise care when nailing corners of lumber. When continuous nailing corners of lumber, a nail may go astray or break through the corner.
- Do not drive a nail on another nail.
- Do not drive a nail on metal parts.

NOTES

- Precautions on no-load operation
Sometimes nailing will continue after driving in all nails previously contained in the magazine. This is termed "no-load operation". Such operation may deteriorate the damper, magazine, and nail feeder.

- To avoid no-load operation, occasionally confirm the amount of remaining nails. On the other hand, all nails should be removed after using this nailer.
- After completing operation, put into the body 5-10 drops oil through the hose joint to protect the tool from rust.
- Under low temperature conditions, the machine sometimes does not operate correctly. Always operate the machine at the appropriate ambient temperature.

2. Adjusting the nailing depth (See Fig. 9)

To assure that each nail penetrates to the same depth, be sure that:

- (1) the air pressure to the Nailer remains constant (regulator is installed and working properly), and
- (2) the Nailer is always held firmly against the workpiece.

If nails are driven too deep or shallow into the workpiece, adjust the nailing in the following order.

- ① DISCONNECT AIR HOSE FROM NAILER.
- ② If nails are driven too deep, turn the adjuster to the shallow side.

Adjustment are in half-turn increments.

If nails are driven too shallow, turn the adjuster to the deep side.

- ③ Stop turning the adjuster when a suitable position is reached for a nailing test.
- ④ Connect the air hose.
ALWAYS WEAR EYE PROTECTOR.
Perform a nailing test.
- ⑤ DISCONNECT AIR HOSE FROM NAILER.
- ⑥ Choose a suitable position for the adjuster.

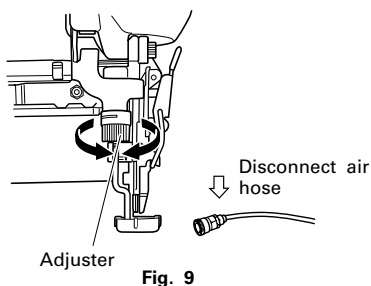

Fig. 9

3. Using the blow nozzle

This Nailer has a blow nozzle that blows out wood shavings which occur during work. Press the knob with your thumb to use the blow nozzle, as shown in the Fig 10.

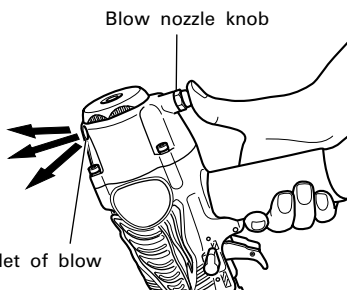

Fig. 10

NOTES

- When the blow nozzle is used for a long time, the nailing force may degrade temporarily. In this case, allows the air supply pressure to stabilize before starting work.
- Oil in the body or drained water from the compressor can sometimes spout out of the air outlet of blow nozzle. It is recommended that you once conduct a test before use and see if such phenomenon happens at an environment where spouted oil will cause any inconvenience.

4. Changing the exhaust direction

The direction of the exhaust vent can be changed by turning the top cover.

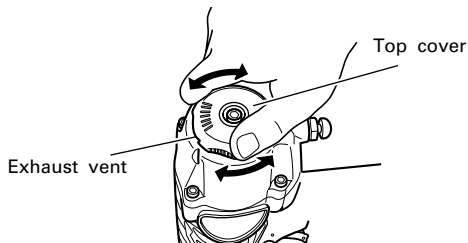

Fig. 11

5. Using the nose cap

If you like to protect the surface of workpiece against scratches or markings made by the push lever, attach the accessory nose cap to the push lever.

- ① DISCONNECT AIR HOSE FROM NAILER.
- ② Put the nose cap to the toe of the push lever.

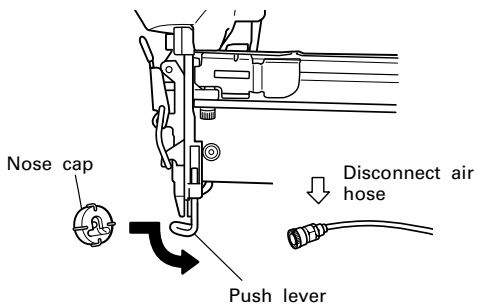

Fig. 12

NOTE

- The nose cap may reduce nailing depth due to its thickness. Re-adjustment of nailing depth is required.

INSPECTION AND MAINTENANCE

CAUTION

Be sure to disconnect the hose during cleaning jams, inspection, maintenance and cleaning.

1. Clearing a jam

Remove a jammed nail in the following order:

- ① DISCONNECT AIR HOSE.
- ② Remove all nails.
- ③ Release the lock lever and open guide plate (A).
- ④ Remove the jammed nail with a slotted-head screwdriver.
- ⑤ Close guide plate (A) and latch.
- ⑥ In case of frequent jam, contact a HIKOKI authorized service center.

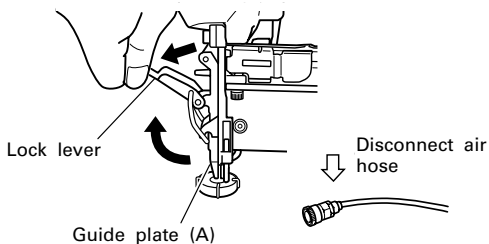

Fig. 13

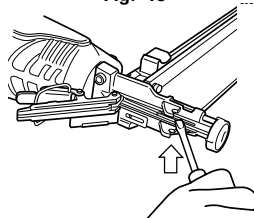

Fig. 14

2. Inspecting the magazine.

- ① DISCONNECT AIR HOSE.
- ② Clean the magazine. Remove dust which may have accumulated in the magazine.
- ③ Lubricate the nail rail with HiKOKI pneumatic tool lubricant.

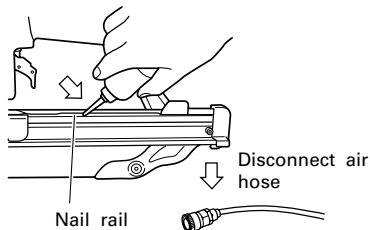

Fig. 15

3. Storing

- When not in use for an extended period, apply a thin coat of the lubricant to the steel parts to avoid rust.
 - Do not store the Nailer in a cold weather environment. Keep the Nailer in a warm area.
 - When not in use, the Nailer should be stored in a warm and dry place.
- Keep out of reach of children.

4. Service parts list

- A: Item No.
B: Code No.
C: No. Used
D: Remarks

CAUTION

Repair, modification and inspection of HiKOKI Power Tools must be carried out by a HiKOKI Authorized Service Center.

This Parts List will be helpful if presented with the tool to the HiKOKI Authorized Service Center when requesting repair or other maintenance.

In the operation and maintenance of power tools, the safety regulations and standards prescribed in each country must be observed.

MODIFICATION

HiKOKI Power Tools are constantly being improved and modified to incorporate the latest technological advancements.

Accordingly, some parts (i.e. code numbers and/or design) may be changed without prior notice.

COMPRESSOR

CAUTION

When the maximum, operating pressure of the air compressor exceeds 8.3 bar (120 psi.), be sure to provide a reducing valve between the air compressor and nailer. Then, adjust the air pressure within the operating range of 4.9 – 8.3 bar (70 – 120 psi.). If the air set is installed, lubrication is also possible, thus providing additional convenience.

OILER-FILTER-REDUCING VALVE (Air Set)

So that the equipment can be operated under an optimum condition to ensure extended service life, it is recommended to use an oiler filter reducing valve. Please limit the length of the hose between the unit and the air set to within 10m when using.

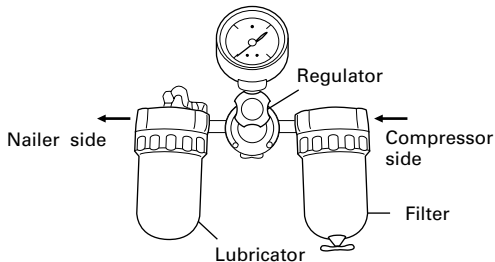

Fig. 16

APPLICABLE LUBRICANTS

Type of lubricant	Name of lubricant
Recommended oil	SHELL TONNA
Motor oil	SAE10W, SAE20W
Turbine oil	ISO VG32 – 68 (#90 – #180)

NOTE

Due to HiKOKI's continuing program of research and development, the specifications herein are subject to change without prior notice.

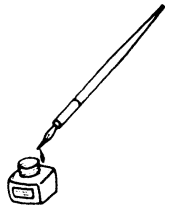

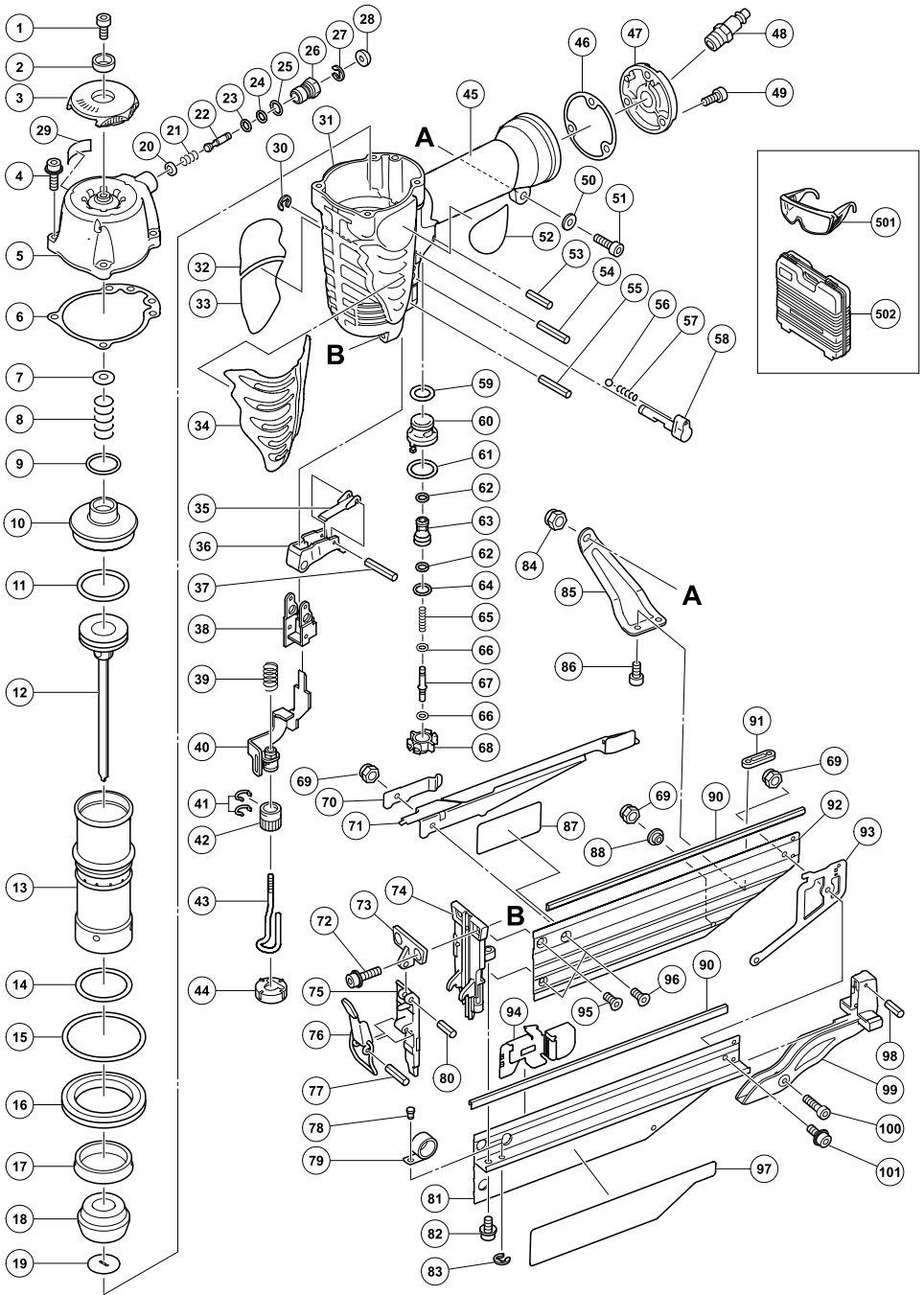

A	B	C	D	A	B	C	D
1	949657	1	M6×12	57	982454	1	
2	880515	1		58	885658	1	
3	885673	1		59	877763	1	I.D 14
4	885637	4	M5×25	60	884963	1	
5	885671	1		61	873570	1	P-18
6	885672	1		62	676531	2	P-7
7	882914	1		63	884964	1	
8	882913	1		64	872654	1	1AP-10
9	883992	1	I.D 20.8	65	884966	1	
10	882927	1		66	878888	2	I.D 1.8
11	885668	1	I.D 31.7	67	884965	1	
12	885667	1		68	884962	1	
13	885663	1		69	876465	3	
14	885690	1	S-44	70	885646	1	
15	885665	1	I.D 59.6	71	885648	1	
16	885664	1		72	885637	2	M5×25
17	885666	1		73	885635	1	
18	885669	1		74	885636	1	
19	885670	1		75	885634	1	
20	884338	1		76	884323	1	
21	881900	1		77	949685	1	D3×20
22	884333	1		78	885656	1	
23	881715	1	P3	79	885655	1	
24	873093	1	1AP-3	80	949770	1	D4×14
25	987105	1	S-10	81	885641	1	
26	882701	1		82	885652	1	M5×12
27	968643	1		83	872971	1	
28	884334	1		84	877371	1	M5
29	_____	1		85	885659	1	
30	955479	1		86	949812	2	M4×10
31	885662	1	"45"	87	_____	1	
32	_____	1		88	885649	1	
33	_____	1		90	885643	2	
34	885675	1		91	885660	1	
35	885689	1		92	885642	1	
36	885657	1	"35, 37"	93	885644	1	
37	881951	1		94	885654	1	
38	885640	1		95	885651	1	M4×6
39	885638	1		96	885650	2	M4×10
40	885639	1		97	_____	1	
41	881765	2		98	878791	1	D2.5×12
42	884325	1		99	885645	1	
43	885688	1		100	949754	1	M4×16
44	881751	1		101	885653	1	M4×14
45	_____	1		501	885549	1	
46	884342	1		502	885676	1	
47	885674	1					
48	_____	1					
49	949821	3	M5×16				
50	885661	1					
51	949757	1	M5×20				
52	_____	1					
53	949539	1	D3×25				
54	884975	1	D3×32				
55	949866	1	D3×30				
56	959155	1	D3.97				

Koki Holdings Co., Ltd.

Shinagawa Intercity Tower A, 15-1, Konan 2-chome,
Minato-ku, Tokyo, 108-6020 Japan

806

Code No. C99146711
Printed in Taiwan