

HiKOKI

Cordless Planer

P 14DSL · P 18DSL

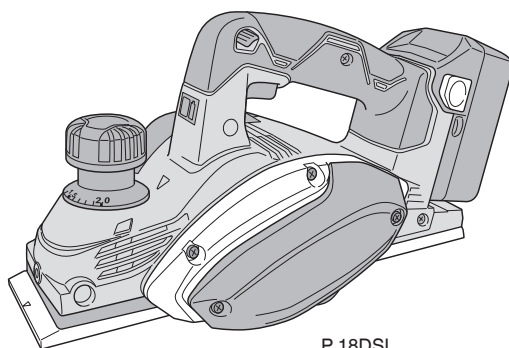

P 18DSL

Read through carefully and understand these instructions before use.

Handling instructions

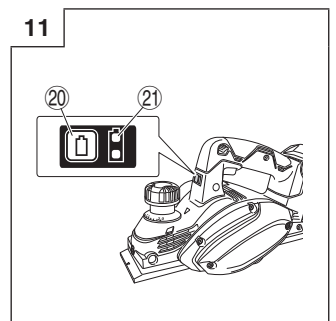
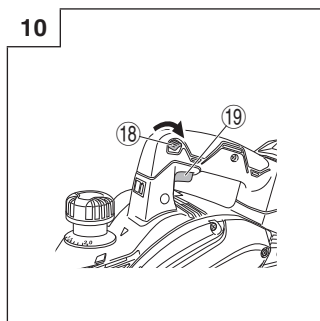
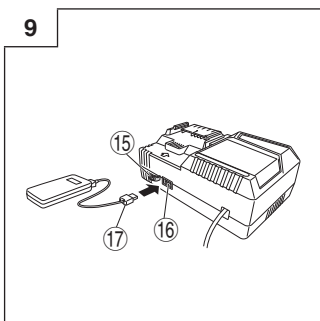
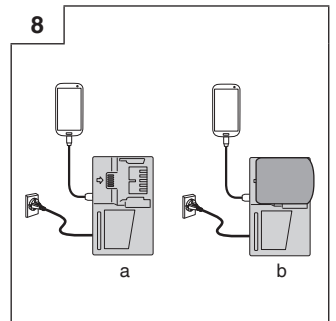
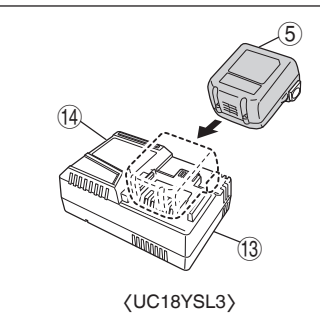
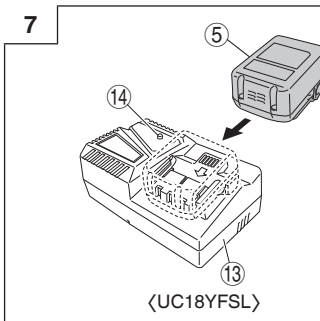
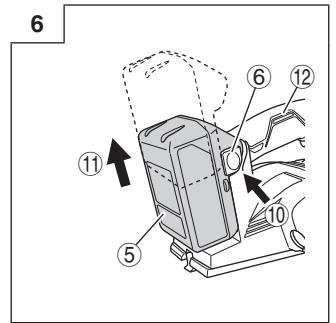
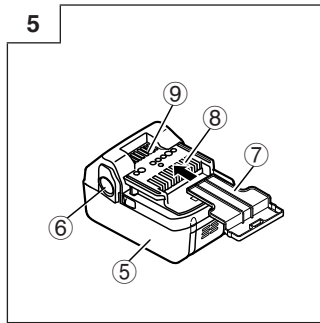
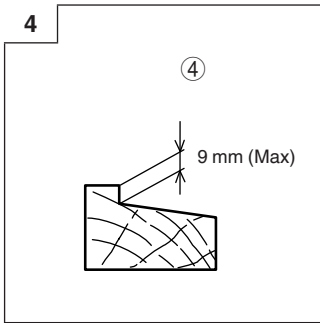
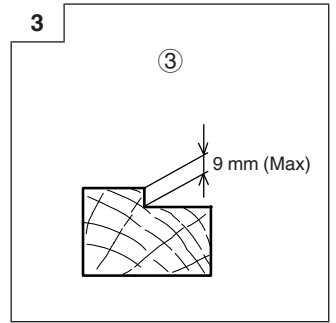
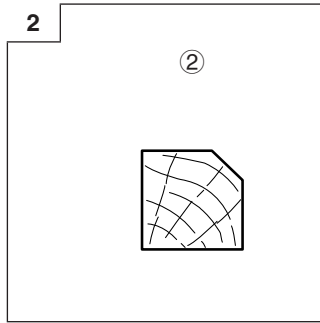
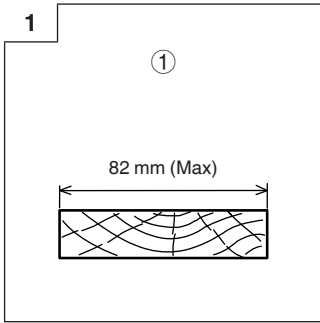

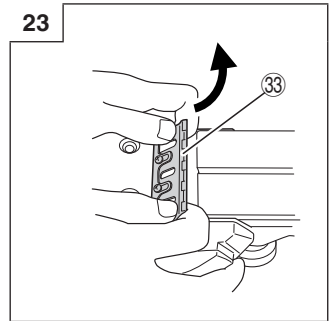
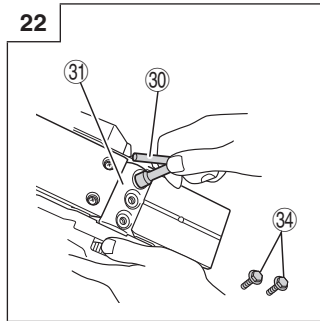
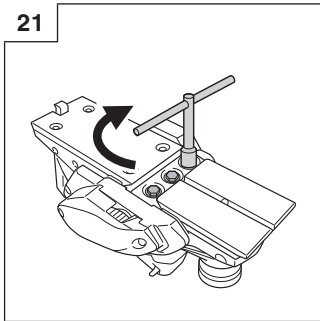
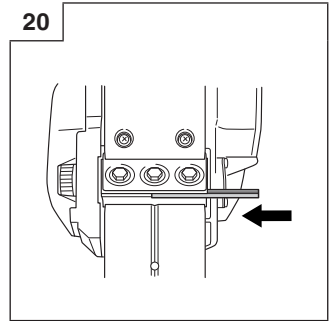
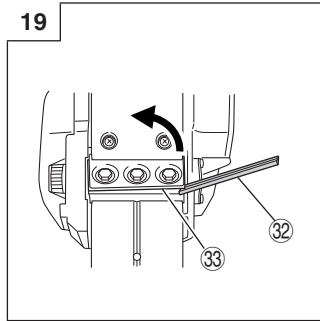
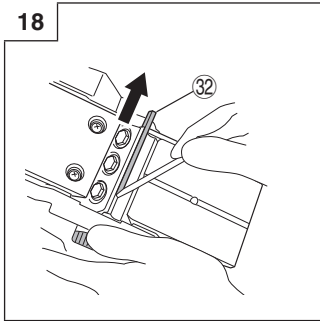
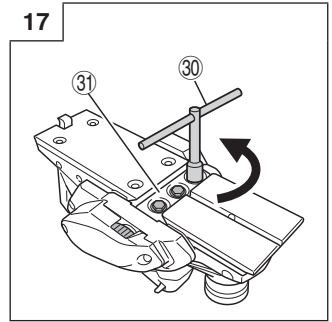
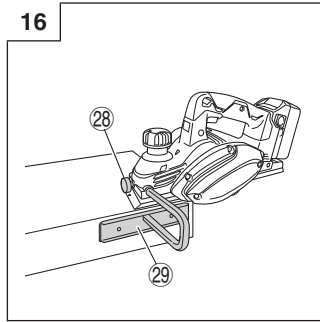
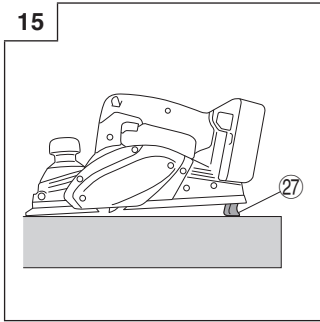
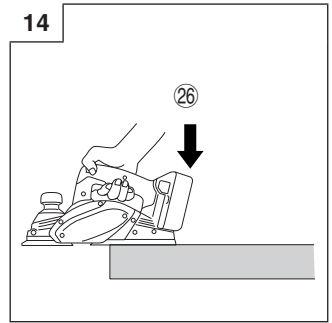
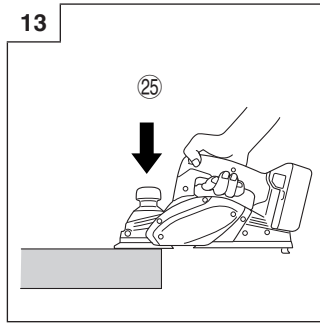
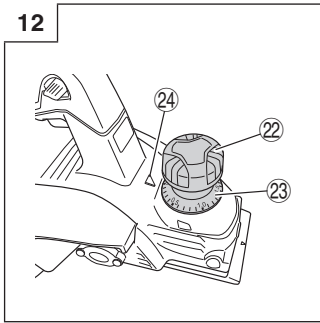

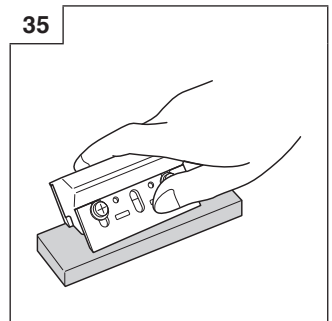
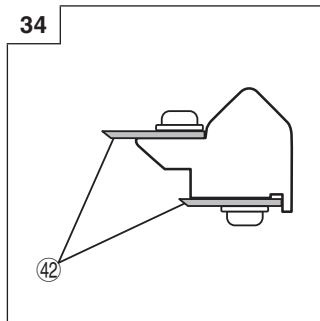
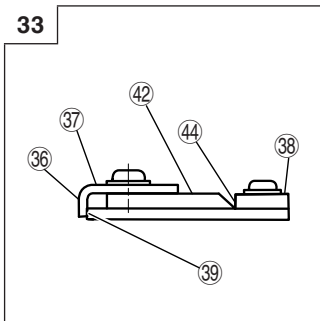
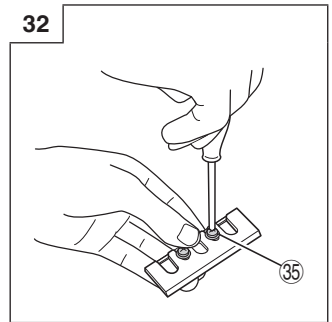
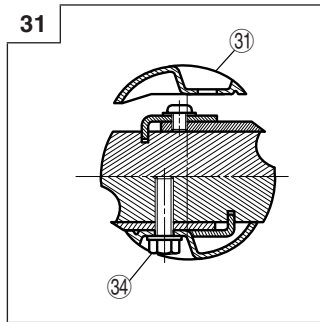
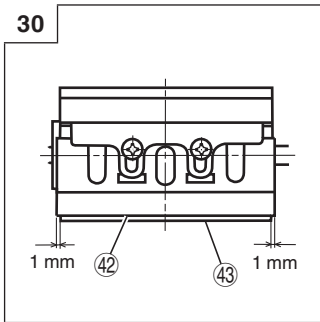
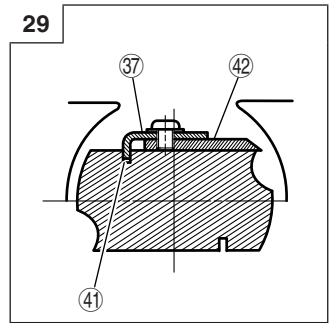
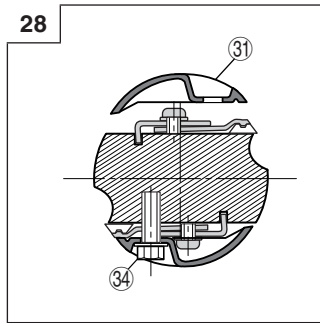
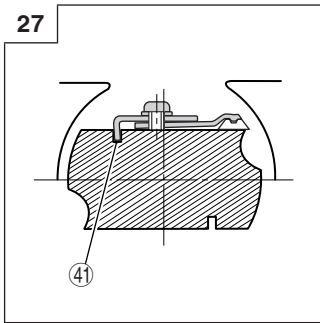
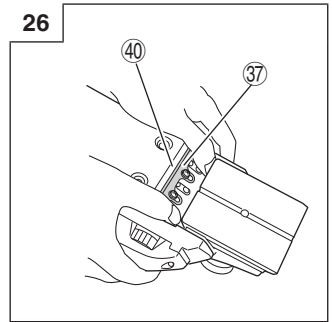
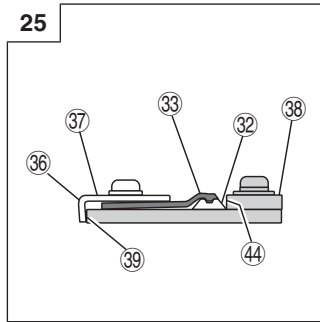
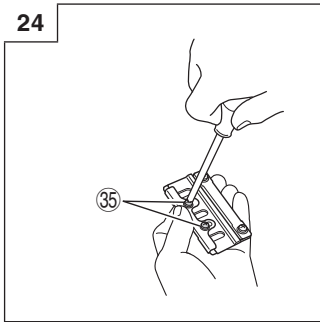

36

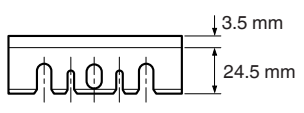

37

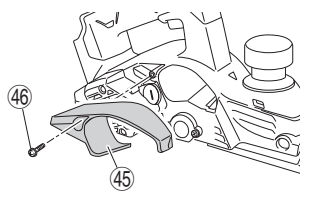

38

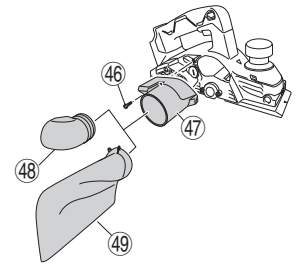

39

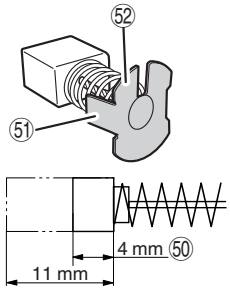

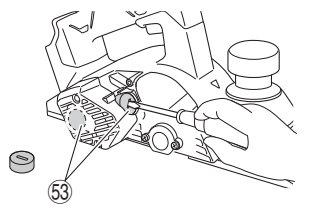

40

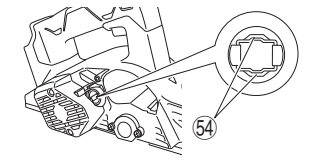

41



①	Planing	⑱	Switch trigger	③⑦	Set plate (A)
②	Beveling	⑳	Remaining battery indicator switch	③⑧	Set gauge
③	Rabbering	㉑	Remaining battery indicator lamp	③⑨	Wall surface b
④	Tapering	㉒	Knob	④⑩	Flat portion of the cutter block
⑤	Rechargeable battery	㉓	Scale	④①	Groove
⑥	Latch	㉔	Mark	④②	Blade (Resharpenable blade type)
⑦	Battery cover	㉕	Beginning of cutting operation	④③	Cutter block
⑧	Terminals	㉖	End of cutting operation	④④	Wall surface a
⑨	Ventilation holes	㉗	Stand	④⑤	Chip cover
⑩	Push	㉘	Set screw	④⑥	Screw D4 × 16
⑪	Pull out	㉙	Guide	④⑦	Dust adapter
⑫	Handle	③⑩	Box wrench	④⑧	Elbow
⑬	Charger	③①	Blade holder	④⑨	Dust bag
⑭	Pilot lamp/Change indicator lamp	③②	Carbide blade (Double edged blade type)	⑤⑩	Wear limit
⑮	Rubber cover	③③	Set plate (B)	⑤①	Nail of carbon brush
⑯	USB port	③④	Bolt	⑤②	Protrusion of carbon brush
⑰	USB cable	③⑤	Machine screw	⑤③	Brush cap
⑱	Switch lock	③⑥	Turned surface	⑤④	Contact portion outside brush tube

	Symbols  WARNING The following show symbols used for the machine. Be sure that you understand their meaning before use.
n_0	no-load speed
/min	Revolutions or reciprocations per minute
==	Direct current
	Caution
V	Volts
kg	Kilograms

GENERAL POWER TOOL SAFETY WARNINGS

WARNING

Read all safety warnings and all instructions.

Failure to follow the warnings and instructions may result in electric shock, fire and/or serious injury.

Save all warnings and instructions for future reference.

The term "power tool" in the warnings refers to your mains-operated (corded) power tool or battery-operated (cordless) power tool.

1) Work area safety

- a) **Keep work area clean and well lit.**
Cluttered or dark areas invite accidents.
- b) **Do not operate power tools in explosive atmospheres, such as in the presence of flammable liquids, gases or dust.**
Power tools create sparks which may ignite the dust or fumes.
- c) **Keep children and bystanders away while operating a power tool.**
Distractions can cause you to lose control.

2) Electrical safety

- a) **Power tool plugs must match the outlet. Never modify the plug in any way. Do not use any adapter plugs with earthed (grounded) power tools.**
Unmodified plugs and matching outlets will reduce risk of electric shock.
- b) **Avoid body contact with earthed or grounded surfaces, such as pipes, radiators, ranges and refrigerators.**
There is an increased risk of electric shock if your body is earthed or grounded.
- c) **Do not expose power tools to rain or wet conditions.**
Water entering a power tool will increase the risk of electric shock.
- d) **Do not abuse the cord. Never use the cord for carrying, pulling or unplugging the power tool. Keep cord away from heat, oil, sharp edges or moving parts.**
Damaged or entangled cords increase the risk of electric shock.
- e) **When operating a power tool outdoors, use an extension cord suitable for outdoor use.**
Use of a cord suitable for outdoor use reduces the risk of electric shock.
- f) **If operating a power tool in a damp location is unavoidable, use a residual current device (RCD) protected supply.**
Use of an RCD reduces the risk of electric shock.

3) Personal safety

- a) **Stay alert, watch what you are doing and use common sense when operating a power tool. Do not use a power tool while you are tired or under the influence of drugs, alcohol or medication.**
A moment of inattention while operating power tools may result in serious personal injury.
- b) **Use personal protective equipment. Always wear eye protection.**
Protective equipment such as dust mask, non-skid safety shoes, hard hat, or hearing protection used for appropriate conditions will reduce personal injuries.
- c) **Prevent unintentional starting. Ensure the switch is in the off-position before connecting to power source and/or battery pack, picking up or carrying the tool.**

Carrying power tools with your finger on the switch or energising power tools that have the switch on invites accidents.

- d) **Remove any adjusting key or wrench before turning the power tool on.**
A wrench or a key left attached to a rotating part of the power tool may result in personal injury.
 - e) **Do not overreach. Keep proper footing and balance at all times.**
This enables better control of the power tool in unexpected situations.
 - f) **Dress properly. Do not wear loose clothing or jewellery. Keep your hair, clothing and gloves away from moving parts.**
Loose clothes, jewellery or long hair can be caught in moving parts.
 - g) **If devices are provided for the connection of dust extraction and collection facilities, ensure these are connected and properly used.**
Use of dust collection can reduce dust-related hazards.
- #### 4) Power tool use and care
- a) **Do not force the power tool. Use the correct power tool for your application.**
The correct power tool will do the job better and safer at the rate for which it was designed.
 - b) **Do not use the power tool if the switch does not turn it on and off.**
Any power tool that cannot be controlled with the switch is dangerous and must be repaired.
 - c) **Disconnect the plug from the power source and/or the battery pack from the power tool before making any adjustments, changing accessories, or storing power tools.**
Such preventive safety measures reduce the risk of starting the power tool accidentally.
 - d) **Store idle power tools out of the reach of children and do not allow persons unfamiliar with the power tool or these instructions to operate the power tool.**
Power tools are dangerous in the hands of untrained users.
 - e) **Maintain power tools. Check for misalignment or binding of moving parts, breakage of parts and any other condition that may affect the power tool's operation. If damaged, have the power tool repaired before use.**
Many accidents are caused by poorly maintained power tools.
 - f) **Keep cutting tools sharp and clean.**
Properly maintained cutting tools with sharp cutting edges are less likely to bind and are easier to control.
 - g) **Use the power tool, accessories and tool bits etc. in accordance with these instructions, taking into account the working conditions and the work to be performed.**
Use of the power tool for operations different from those intended could result in a hazardous situation.
- #### 5) Battery tool use and care
- a) **Recharge only with the charger specified by the manufacturer.**
A charger that is suitable for one type of battery pack may create a risk of fire when used with another battery pack.
 - b) **Use power tools only with specifically designated battery packs.**

Use of any other battery packs may create a risk of injury and fire.

- c) **When battery pack is not in use, keep it away from other metal objects, like paper clips, coins, keys, nails, screws or other small metal objects, that can make a connection from one terminal to another.**

Shorting the battery terminals together may cause burns or a fire.

- d) **Under abusive conditions, liquid may be ejected from the battery; avoid contact. If contact accidentally occurs, flush with water. If liquid contacts eyes, additionally seek medical help.**

Liquid ejected from the battery may cause irritation or burns.

6) **Service**

- a) **Have your power tool serviced by a qualified repair person using only identical replacement parts.**

This will ensure that the safety of the power tool is maintained.

PRECAUTION

Keep children and infirm persons away.

When not in use, tools should be stored out of reach of children and infirm persons.

CORDLESS PLANER SAFETY WARNINGS

1. **Wait for the cutter to stop before settling the tool down.**

An exposed rotating cutter may engage the surface leading to possible loss of control and serious injury.

2. **Use clamps or another practical way to secure and support the workpiece to a stable platform.**

Holding the work by your hand or against the body leaves it unstable and may lead to loss of control.

3. **Do not use the Planer with the blades facing upward (as stationary type planer).**

4. **Do not allow foreign matter to enter the hole for connecting the rechargeable battery.**

5. **Never disassemble the rechargeable battery and charger.**

6. **Never short-circuit the rechargeable battery.** Short-circuiting the battery will cause a great electric current and overheat. It results in burn or damage to the battery.

7. **Do not dispose of the battery in fire.** If the battery is burnt, it may explode.

8. **Do not insert object into the air ventilation slots of the charger.**

Inserting metal objects or inflammables into the charger air ventilation slots will result in electrical shock hazard or damaged charger.

9. **Bring the battery to the shop from which it was purchased as soon as the post-charging battery life becomes too short for practical use. Do not dispose of the exhausted battery.**

10. **Using an exhausted battery will damage the charger.**

CAUTION ON LITHIUM-ION BATTERY

To extend the lifetime, the lithium-ion battery equips with the protection function to stop the output.

In the cases of 1 to 3 described below, when using this product, even if you are pulling the switch, the motor may stop. This is not the trouble but the result of protection function.

1. When the battery power remaining runs out, the motor stops.
In such case, charge it up immediately.
2. If the tool is overloaded, the motor may stop. In this case, release the switch of tool and eliminate causes of overloading. After that, you can use it again.
3. If the battery is overheated under overload work, the battery power may stop.
In this case, stop using the battery and let the battery cool. After that, you can use it again.

Furthermore, please heed the following warning and caution.

WARNING

In order to prevent any battery leakage, heat generation, smoke emission, explosion and ignition beforehand, please be sure to heed the following precautions.

1. Make sure that swarf and dust do not collect on the battery.
 - During work make sure that swarf and dust do not fall on the battery.
 - Make sure that any swarf and dust falling on the power tool during work do not collect on the battery.
 - Do not store an unused battery in a location exposed to swarf and dust.
 - Before storing a battery, remove any swarf and dust that may adhere to it and do not store it together with metal parts (screws, nails, etc.).
2. Do not pierce battery with a sharp object such as a nail, strike with a hammer, step on, throw or subject the battery to severe physical shock.
3. Do not use an apparently damaged or deformed battery.
4. Do not use the battery in reverse polarity.
5. Do not connect directly to an electrical outlets or car cigarette lighter sockets.
6. Do not use the battery for a purpose other than those specified.
7. If the battery charging fails to complete even when a specified recharging time has elapsed, immediately stop further recharging.
8. Do not put or subject the battery to high temperatures or high pressure such as into a microwave oven, dryer, or high pressure container.
9. Keep away from fire immediately when leakage or foul odor are detected.
10. Do not use in a location where strong static electricity generates.
11. If there is battery leakage, foul odor, heat generated, discolored or deformed, or in any way appears abnormal during use, recharging or storage, immediately remove it from the equipment or battery charger, and stop use.

CAUTION

1. If liquid leaking from the battery gets into your eyes, do not rub your eyes and wash them well with fresh clean water such as tap water and contact a doctor immediately. If left untreated, the liquid may cause eye-problems.
2. If liquid leaks onto your skin or clothes, wash well with clean water such as tap water immediately. There is a possibility that this can cause skin irritation.
3. If you find rust, foul odor, overheating, discolor, deformation, and/or other irregularities when using the battery for the first time, do not use and return it to your supplier or vendor.

WARNING

If an electrically conductive foreign object enters the terminals of the lithium ion battery, a short-circuit may occur resulting in the risk of fire. Please observe the following matters when storing the battery.

- **Do not place electrically conductive cuttings, nails, steel wire, copper wire or other wire in the storage case.**

- Either install the battery in the power tool or store by securely pressing into the battery cover until the ventilation holes are concealed to prevent short-circuits (See Fig. 5).

REGARDING LITHIUM-ION BATTERY TRANSPORTATION

When transporting a lithium-ion battery, please observe the following precautions.

WARNING

Notify the transporting company that a package contains a lithium-ion battery, inform the company of its power output and follow the instructions of the transportation company when arranging transport.

- Lithium-ion batteries that exceed a power output of 100Wh are considered to be in the freight classification of Dangerous Goods and will require special application procedures.
- For transportation abroad, you must comply with international law and the rules and regulations of the destination country.

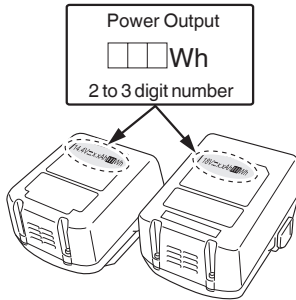

USB DEVICE CONNECTION PRECAUTIONS (ONLY WITH UC18YSL3 CHARGER)

When an unexpected problem occurs, the data in a USB device connected to this product may be corrupted or lost. Always make sure to back up any data contained in the USB device prior to use with this product.

Please be aware that our company accepts absolutely no responsibility for any data stored in a USB device that is corrupted or lost, nor for any damage that may occur to a connected device.

WARNING

- Prior to use, check the connecting USB cable for any defect or damage. Using a defective or damaged USB cable can cause smoke emission or ignition.
- When the product is not being used, cover the USB port with the rubber cover. Buildup of dust etc. in the USB port can cause smoke emission or ignition.

NOTE

- There may be an occasional pause during USB recharging.
- When a USB device is not being charged, remove the USB device from the charger. Failure to do so may not only reduce the battery life of a USB device, but may also result in unexpected accidents.
- It may not be possible to charge some USB devices, depending on the type of device.

SPECIFICATIONS

POWER TOOL

Model		P14DSL	P18DSL
Cutting Width		82 mm	
Max. Cutting Depth		2.0 mm	
No-load speed		16000 /min	
Rechargeable battery	2LSRK	BSL1430: Li-ion 14.4 V (3.0 Ah 8 cells)	BSL1830: Li-ion 18 V (3.0 Ah 10 cells)
	2LJRK	BSL1450: Li-ion 14.4 V (5.0 Ah 8 cells)	BSL1850: Li-ion 18 V (5.0 Ah 10 cells)
	2LYCK	—	BSL1860: Li-ion 18 V (6.0 Ah 10 cells)
Weight		3.2 kg (With BSL1430)	3.3 kg (With BSL1830)

CHARGER

Model	UC18YFSL	UC18YSL3
Charging voltage	14.4 V – 18 V	
Weight	0.5 kg	0.6 kg

STANDARD ACCESSORIES

In addition to the main unit (1), the package contains the accessories listed in the table below.

P14DSL (2LSRK) (2LJRK)	① Box Wrench 1 (for securing cutter blade)	
	② Set Gauge 1 (for adjusting cutter height)	
	③ Guide 1 (with set screw)	
	④ Carbide Blade 2 (Double edged Blade type)	
	⑤ Charger 1	
	P18DSL (2LSRK) (2LJRK) (2LYCK)	⑥ Battery 2 [P14DSL] BSL1430 or BSL1450 [P18DSL] BSL1830 or BSL1850 or BSL1860
		⑦ Plastic case 1
		⑧ Battery cover 2
		⑨ Spare carbide Blade set 1 (Not supplied in all areas)
		⑩ Blade Sharpening Ass'y 1 (for Resharpenable Blade Type)
P14DSL (NN) P18DSL (NN)	① Box Wrench 1 (for securing cutter blade)	
	② Set Gauge 1 (for adjusting cutter height)	
	③ Guide 1 (with set screw)	
	④ Carbide Blade 2 (Double edged Blade type)	
	⑤ Blade Sharpening Ass'y 1 (for Resharpenable Blade Type)	
Without charger, battery, plastic case and battery cover.		

Standard accessories are subject to change without notice.

OPTIONAL ACCESSORIES (sold separately)

1. Battery

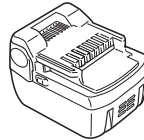

(BSL1430)
(BSL1440)
(BSL1450)

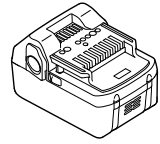

(BSL1830)
(BSL1840)
(BSL1850)
(BSL1860)

2. Dust adapter

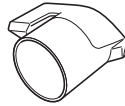

3. Elbow



4. Dust bag



5. Carbide Blade

(Double edged Blade type)

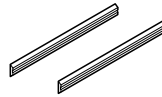

6. Blade

(Resharpenable blade type)

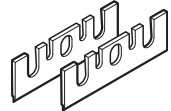

Optional accessories are subject to change without notice.

APPLICATIONS

Planing various wooden planks and panels. (See Fig. 1-4)

BATTERY REMOVAL/INSTALLATION

1. Battery removal

Hold the handle tightly and push the battery latch to remove the battery (see Figs. 5 and 6).

CAUTION

Never short-circuit the battery.

2. Battery installation

Insert the battery while observing its polarities (see Fig. 6).

CHARGING

Before using the power tool, charge the battery as follows.

1. Connect the charger's power cord to the receptacle.

<UC18YFSL>

When connecting the plug of the charger to a receptacle, the pilot lamp will blink in red (At 1-second intervals).

<UC18YSL3>

When connecting the plug of the charger to a receptacle, the charge indicator lamp will blink in red (At 1-second intervals).

CAUTION

Do not use the electrical cord if damaged. Have it repaired immediately.

2. Insert the battery into the charger. (Fig. 7)

Firmly insert the battery into the charger.

3. Charging

<UC18YFSL>

When inserting a battery in the charger, the pilot lamp will light up continuously in red.

When the battery becomes fully recharged, the pilot lamp will blink in red (At 1-second intervals). (See **Table 1-a**)

● Pilot lamp indication

The indications of the pilot lamp will be as shown in **Table 1-a**, according to the condition of the charger or the rechargeable battery.

<UC18YSL3>

When inserting a battery in the charger, the charge indicator lamp will blink in blue.

When the battery becomes fully recharged, the charge indicator lamp will light up in green. (See **Table 1-b**)

● Charge indicator lamp indication

The indications of the charge indicator lamp will be as shown in **Table 1-b**, according to the condition of the charger or the rechargeable battery.

Table 1-a

Indications of the pilot lamp				
Pilot lamp (red)	Before charging	Blinks	Lights for 0.5 seconds. Does not light for 0.5 seconds. (off for 0.5 seconds)	/
	While charging	Lights	Lights continuously	
	Charging complete	Blinks	Lights for 0.5 seconds. Does not light for 0.5 seconds. (off for 0.5 seconds)	
	Overheat standby	Blinks	Lights for 1 second. Does not light for 0.5 seconds. (off for 0.5 seconds)	Battery overheated. Unable to charge. (Charging will commence when battery cools)
	Charging impossible	Flickers	Lights for 0.1 seconds. Does not light for 0.1 seconds. (off for 0.1 seconds)	Malfunction in the battery or the charger

NOTE: When standby for cooling battery, UC18YFSL cools the overheated battery by cooling fan.

Table 1-b

Indications of the charge indicator lamp				
Charge indicator lamp (red / blue / green / purple)	Before charging	Blinks (red)	Lights for 0.5 seconds. Does not light for 0.5 seconds. (off for 0.5 seconds)	Plugged into power source
	While charging	Blinks (blue)	Lights for 0.5 seconds. Does not light for 1 second. (off for 1 second)	Battery capacity at less than 50%
		Blinks (blue)	Lights for 1 second. Does not light for 0.5 seconds. (off for 0.5 seconds)	Battery capacity at less than 80%
		Lights (blue)	Lights continuously	Battery capacity at more than 80%
	Charging complete	Lights (green)	Lights continuously (Continuous buzzer sound: about 6 seconds)	/
	Overheat standby	Blinks (red)	Lights for 0.3 seconds. Does not light for 0.3 seconds. (off for 0.3 seconds)	Battery overheated. Unable to charge. (Charging will commence when battery cools)
	Charging impossible	Flickers (purple)	Lights for 0.1 seconds. Does not light for 0.1 seconds. (off for 0.1 seconds) (Intermittent buzzer sound: about 2 seconds)	Malfunction in the battery or the charger

NOTE: When standby for cooling battery, UC18YSL3 cools the overheated battery by cooling fan.

- (2) Regarding the temperatures of the rechargeable battery
The temperatures for rechargeable batteries are as shown in **Table 2**, and batteries that have become hot should be cooled for a while before being recharged.

Table 2 Recharging ranges of batteries

Rechargeable batteries	Temperatures at which the battery can be recharged
BSL1430, BSL1440, BSL1450, BSL1820, BSL1830, BSL1840, BSL1850, BSL1860	0°C – 50°C (UC18YFSL) -10°C – 50°C (UC18YSL3)

- (3) Regarding recharging time
Depending on the combination of the charger and batteries, the charging time will become as shown in **Table 3**.

Table 3 Charging time (At 20°C)

Battery \ Charger	UC18YFSL	UC18YSL3
BSL1820	Approx. 30 min.	Approx. 20 min.
BSL1430, BSL1830	Approx. 45 min.	Approx. 20 min.
BSL1440, BSL1840	Approx. 60 min.	Approx. 26 min.
BSL1450, BSL1850	Approx. 75 min.	Approx. 32 min.
BSL1860	Approx. 90 min.	Approx. 38 min.

NOTE

The recharging time may vary according to the ambient temperature and power source voltage.

CAUTION

When the battery charger has been continuously used, the battery charger will be heated, thus constituting the cause of the failures. Once the charging has been completed, give 15 minutes rest until the next charging.

4. **Disconnect the charger's power cord from the receptacle.**

5. **Hold the charger firmly and pull out the battery.**

NOTE

Be sure to pull out the battery from the charger after use, and then keep it.

How to make the batteries perform longer

- (1) Recharge the batteries before they become completely exhausted.
When you feel that the power of the tool becomes weaker, stop using the tool and recharge its battery. If you continue to use the tool and exhaust the electric current, the battery may be damaged and its life will become shorter.
- (2) Avoid recharging at high temperatures.
A rechargeable battery will be hot immediately after use. If such a battery is recharged immediately after use, its internal chemical substance will deteriorate, and the battery life will be shortened. Leave the battery and recharge it after it has cooled for a while.

CAUTION

- If the battery is charged while it is heated because it has been left for a long time in a location subject to direct sunlight or because the battery has just been used, the pilot lamp of UC18YFSL charger lights for 1 second, does not light for 0.5 seconds (off for 0.5 seconds), or the charge indicator lamp of UC18YSL3 charger lights for 0.3 seconds, does not light for 0.3 seconds (off for 0.3 seconds). In such a case, first let the battery cool, then start charging.

- When the pilot lamp or charge indicator lamp flickers in red (at 0.2-seconds intervals), check for and take out any foreign objects in the charger's battery connector. If there are no foreign objects, it is probable that the battery or charger is malfunctioning. Take it to your authorized Service Center.
- Since the built-in micro computer takes about 3 seconds to confirm that the battery being charged with charger is taken out, wait for a minimum of 3 seconds before reinserting it to continue charging. If the battery is reinserted within 3 seconds, the battery may not be properly charged.
- If the pilot lamp or charge indicator lamp does not blink in red (every second) even though the charger cord is connected to the power, it indicates that the protection circuit of the charger may be activated. Remove the cord from the power and then connect it again after 30 seconds or so. If this does not cause the pilot lamp or charge indicator lamp to blink in red (every second), please take the charger to the HIKOKI Authorized Service Center.

HOW TO RECHARGE USB DEVICE (ONLY WITH UC18YSL3 CHARGER)

- (1) Select a charging method
Depending on the charge method selected, either the battery is inserted into the charger or the power cord is plugged into an outlet.
- Charging a USB device from an electrical outlet (**Fig. 8-a**)
 - Charging a USB device and battery from an electrical outlet (**Fig. 8-b**)
- (2) Connect the USB cable. (**Fig. 9**)
Pull back the rubber cover and firmly plug in a commercially available USB cable (appropriate to the device being charged) into the USB port.
- (3) When charging is completed
- To verify charge status, check the USB device.
 - Unplug the power cord from the electrical outlet.
 - Place the rubber cover over the USB port.

PRIOR TO OPERATION

1. **Setting up and checking the work environment**
Check if the work environment is suitable by following the precautions.
2. **Power switch**
Ensure that the power switch is in the OFF position. If the battery is attached to the body while the power switch is in the ON position, the power tool will start operating immediately, which could cause a serious accident.
3. Prepare a stable wooden workbench suitable for planing operation. As a poorly balanced workbench creates a hazard, ensure it is securely positioned on firm, level ground.

PLANING PROCEDURES

1. Operation of switch (Fig. 10)

- (1) For safe operation of the machine, a "switch lock" is provided on the side of a handle.
If the "switch trigger" is pulled in a state where "switch lock" is pressed in the direction of the arrow mark, the main switch can be turned ON.
- (2) After the switch is turned ON, even when you release your hand from the switch lock, the body continues running and the light continues being turned ON as long as you keep on pulling the switch trigger.
- (3) If you release the switch trigger, you can turn OFF the switch and the "switch lock" returns to the original position automatically.



CAUTION

Do not fix and secure the switch lock. Besides, keep your finger off the switch trigger when the planer is being carried around. Otherwise, the main body switch can be inadvertently turned ON, resulting in unexpected accidents.

2. About remaining battery indicator

When pressing the remaining battery indicator switch, the remaining battery indicator lamp lights and the battery remaining power can be checked. (Fig. 11)
When releasing your finger from the remaining battery indicator switch, the remaining battery indicator lamp goes off. The Table 4 shows the state of remaining battery indicator lamp and the battery remaining power.

Table 4

State of lamp	Battery Remaining Power
	The battery remaining power is enough.
	The battery remaining power is a half.
	The battery remaining power is nearly empty. Re-charge the battery soonest possible.

As the remaining battery indicator shows somewhat differently depending on ambient temperature and battery characteristics, read it as a reference.

NOTE

- Do not give a strong shock to the switch panel or break it. It may lead to a trouble.
 - To save the battery power consumption, the remaining battery indicator lamp lights while pressing the remaining battery indicator switch.
- ### 3. Adjusting the cutter depth
- (1) Turn the knob in the direction indicated by the arrow in Fig. 12 (clockwise), until the triangular mark is aligned with the desired cutting depth on the scale. The scale unit is graduated in millimeters.
 - (2) The cutting depth can be adjusted within a range of 0-2.0 mm.
- ### 4. Surface cutting
- Rough cutting should be accomplished at large cutting depths and at a suitable speed so that shavings are smoothly ejected from the machine.
To ensure a smoothly finished surface, finish cutting should be accomplished at small cutting depths and at low feeding speed.

5. Beginning and ending the cutting operation

As shown in Fig. 13, place the front base of the planer on the material and support the planer horizontally. Turn ON the power switch, and slowly operate the planer toward the leading edge of the material. Firmly depress the front half of the planer at the first stage of cutting, as shown in Fig. 14, depress the rear half of the planer at the end of the cutting operation. The planer must always be kept flat throughout the entire cutting operation.

6. Precaution after finishing the planing operation

When the planer is suspended with one hand after finishing the planing operation, ensure that the cutting blades (base) of the planer do not contact or come too near your body. Failure to do so could result in serious injury.

7. Stand

Lift the back of the planer to extend the foot from the base. Having the stand extended when you put the planer down prevents contact between the blade and the material. (Fig. 15)

8. Regulating the guide (Fig. 16)

The planing position can be regulated by moving the guide to the left or right after loosening its set screw. The guide may be mounted on either the right or left side of the tool.

Work Precautions

- About Continuous Operation
This tool is provided with a protective function to extend battery life.
The battery may become overheated during continuous operation or deep cutting operations, which may cause it to automatically stop.
Especially with any of the batteries listed below, the tool may stop operation before the battery starts to get hot to prevent rapid failure from overheating.
If this happens, stop operation, remove the battery from the tool and leave it in a well-ventilated location not exposed to sunlight until it is sufficiently cool.
The battery can be used again once it is cool.
(Applicable batteries: BSL1425, BSL1420, BSL1415, BSL1825, BSL1820, BSL1815 and old batteries)
- Proper Battery Usage
When the tool is used with any of the batteries listed below, it should be used for light work to extend battery life.
Work example: Shallow depth finishing and chamfering work
(Applicable batteries: BSL1425, BSL1420, BSL1415, BSL1825, BSL1820, BSL1815 and old batteries)

CARBIDE BLADE ASSEMBLY AND DISASSEMBLY AND ADJUSTMENT OF CUTTER BLADE HEIGHT (FOR DOUBLE EDGED BLADE TYPE)

1. Carbide blade disassembly

CAUTION

- To prevent accidents, ensure that the power tool is switched off and pull out the battery.
- Be careful not to injure your hands.
- (1) As shown in Fig. 17, loosen the blade holder with the attached box wrench.
- (2) As shown in Fig. 18, remove the carbide blade by sliding it with the attached box wrench.

2. Carbide blade assembly

CAUTION

- To prevent accidents, ensure that the power tool is switched off and pull out the battery.
- Prior to assembly, thoroughly wipe off all swarf accumulated on the carbide blade.

- (1) As shown in **Fig. 19**, lift set plate (B) and insert the new carbide blade between cutter block and set plate (B).
- (2) As shown in **Fig. 20**, mount the new carbide blade by sliding it on the set plate (B) so that the blade tip projects by 1mm from the end of the cutter block.
- (3) As shown in **Fig. 21**, fix the bolts at the blade holder after blade replacement has been completed.
- (4) Turn the cutter block over, and set the other side in the same manner.

3. Adjustment of carbide blade height

CAUTION

- To prevent accidents, ensure that the power tool is switched off and pull out the battery.
 - If the carbide blade's heights are inaccurate after above procedures have been completed, carry out the procedures described below.
- (1) As shown in **Fig. 22**, use the box wrench to loosen the three bolts used to retain the carbide blade, and remove the blade holder.
 - (2) As shown in **Fig. 23**, after removing the carbide blade, slide set plate (B) in the direction indicated by the arrow to disassemble set plate (B).
 - (3) Loosen the 2 screws holding on the carbide blade and set plate (A), set plate (B).
 - (4) As shown in **Fig. 24, 25**, press the turned surface of set plate (A) to the wall surface b while adjusting the carbide blade edge to the wall surface a of the set gauge. Then, tighten them with the 2 screws.
 - (5) As shown in **Fig. 26, 27**, insert a turned portion of set plate (A) attached to set plate (B) into a groove on the flat portion of the cutter block.
 - (6) As shown in **Fig. 28**, place the blade holder on the completed assembly and fasten it with the three bolts. Ensure that the bolts are securely tightened. Follow the same procedures for the opposite side carbide blade.

BLADE ASSEMBLY AND DISASSEMBLY AND ADJUSTMENT OF BLADE HEIGHT (FOR RESHARPENABLE BLADE TYPE)

1. Blade disassembly

CAUTION

- To prevent accidents, ensure that the power tool is switched off and pull out the battery.
 - Be careful not to injure your hands.
- (1) As shown in **Fig. 22**, use the accessory box wrench to loosen the three bolts used to retain the blade, and remove the blade holder.
 - (2) As shown in **Fig. 23**, slide the blade in the direction indicated by the arrow to disassemble the blade.

2. Blade assembly

CAUTION

- To prevent accidents, ensure that the power tool is switched off and pull out the battery.
 - Prior to assembly, thoroughly wipe off all swarf accumulated on the blade.
- (1) Insert a turned portion of set plate (A) attached to the blade into a groove on the flat portion of the cutter block. (**Fig. 26, 29**)
Set the blade so that both sides of the blade protrude from the width of the cutter block by about 1 mm (**Fig. 30**)
 - (2) Place the blade holder on the completed assembly, as shown in **Fig. 31**, and fasten it with the three bolts. Ensure that the bolts are securely tightened.
 - (3) Turn the cutter block over, and set the opposite side in the same manner.

3. Adjustment of blade height

- (1) Loosen the 2 screws holding on the blade and set plate (A). (**Fig. 32**)
- (2) Press the turned surface of set plate (A) to the wall surface b while adjusting the blade edge to the wall surface a of the set gauge. Then, tighten them with the 2 screws. (**Fig. 24, 33**)

SHARPENING THE RESHARPENABLE BLADES

Use of the accessory Blade Sharpening Ass'y is recommended for convenience.

1. Use of Blade Sharpening Ass'y

As shown in **Fig. 34**, two blades can be mounted on the blade sharpening ass'y to ensure that the blade tips are ground at uniform angles. During grinding, adjust the position of the blades so that their edges simultaneously contact the dressing stone as shown in **Fig. 35**.

2. Blade sharpening intervals

Blade sharpening intervals depend on the type of wood being cut and the cutting depth. However, sharpening should generally be effected after each 500 meters of cutting operation.

3. Grinding allowance of the cutter blades

As illustrated in **Fig. 36**, a grinding allowance of 3.5mm is provided for on the cutter blade. That is, the cutter blade can be repeatedly sharpened until its total height is reduced to 24.5 mm.

4. Grinding Stone

When a water grinding stone is available, use it after dipping it sufficiently in water since such a grinding stone may be worn during grinding procedures, flatten the upper surface of the grinding stone as frequently as possible.

ATTACHING AND DETACHING THE DUST ADAPTER (OPTIONAL ACCESSORY)

CAUTION

- To prevent accidents, ensure that the power tool is switched off and pull out the battery.
- Follow the procedure below to mount the dust adapter securely. Failure to do so may result in the adapter coming off, causing injury.

1. Attaching the dust adapter

- (1) Remove the screw D4 x 16 in the chip cover and remove the chip cover as shown in **Fig. 37**.
- (2) Mount the dust adapter and secure with the screw D4 x 16. (**Fig. 38**)

NOTE

Take care not to break the catch when attaching or detaching the dust adapter and chip cover.

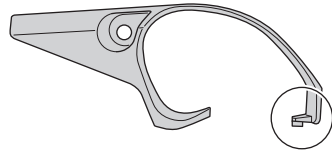

2. Removing the dust adapter

To remove the dust adapter, follow the procedure above in reverse order.

MAINTENANCE AND INSPECTION

1. Inspecting the blades

Continued use of dull or damaged blades will result in reduced cutting efficiency and may cause overloading of the motor. Sharpen or replace the blades as often as necessary.

2. Handling

CAUTION

The front base, rear base, and cutting depth control knob are precisely machined to obtain specifically high precision. If these parts are roughly handled or subjected to heavy mechanical impact, it may cause deteriorated precision and reduced cutting performance. These parts must be handled with particular care.

3. Inspecting the mounting screws

Regularly inspect all mounting screws and ensure that they are properly tightened. Should any of the screws be loose, retighten them immediately. Failure to do so could result in serious hazard

4. Inspecting the carbon brushes (Fig. 39)

The motor employs carbon brushes which are consumable parts. Since and excessively worn carbon brush can result in motor trouble, replace the carbon brush with new ones when it becomes worn to or near the "wear limit". In addition, always keep carbon brushes clean and ensure that they slide freely within the brush holders.

NOTE

When replacing the carbon brush with a new one, be sure to use the HiKOKI Carbon Brush Code No. 999017.

5. Replacing carbon brushes

After removing the chip cover, take out the carbon brush by first removing the brush cap and then hooking the protrusion of the carbon brush with a slotted head screw driver, etc., as shown in Fig. 40.

When installing the carbon brush, choose the direction so that the nail of the carbon brush agrees with the contact portion outside the brush tube. Then push it in with a finger as illustrated in Fig. 41. Lastly, install the brush cap.

CAUTION

Be absolutely sure to insert the nail of the carbon brush into the contact portion outside the brush tube.

(You can insert whichever one of the two nails provided.) Caution must be exercised since any error in this operation can result in the deformed nail of the carbon brush and may cause motor trouble at an early stage.

6. Maintenance of the motor

The motor unit winding is the very "heart" of the power tool.

Exercise due care to ensure the winding does not become damaged and/or wet with oil or water.

7. Cleaning on the outside

When the planer is stained, wipe with a soft dry cloth or a cloth moistened with soapy water. Do not use chloric solvents, gasoline or paint thinner, for they melt plastics.

8. Storage

Store the planer in a place in which the temperature is less than 40°C and out of reach of children.

NOTE

Storing lithium-ion batteries

Make sure the lithium-ion batteries have been fully charged before storing them.

Prolonged storage (3 months or more) of batteries with a low charge may result in performance deterioration, significantly reducing battery usage time or rendering the batteries incapable of holding a charge.

However, significantly reduced battery usage time may be recovered by repeatedly charging and using the batteries two to five times.

If the battery usage time is extremely short despite repeated charging and use, consider the batteries dead and purchase new batteries.

9. Service parts list

CAUTION

Repair, modification and inspection of HiKOKI Power Tools must be carried out by a HiKOKI Authorized Service Center.

This Parts List will be helpful if presented with the tool to the HiKOKI Authorized Service Center when requesting repair or other maintenance.

In the operation and maintenance of power tools, the safety regulations and standards prescribed in each country must be observed.

MODIFICATIONS

HiKOKI Power Tools are constantly being improved and modified to incorporate the latest technological advancements.

Accordingly, some parts may be changed without prior notice.

Important notice on the batteries for the HiKOKI cordless power tools

Please always use one of our designated genuine batteries. We cannot guarantee the safety and performance of our cordless power tool when used with batteries other than those designated by us, or when the battery is disassembled and modified (such as disassembly and replacement of cells or other internal parts).

NOTE

Due to HiKOKI's continuing program of research and development, the specifications herein are subject to change without prior notice.

Item No.	Part Name	QTY
55	CONTROLLER TERMINAL SET (W/FERRITE CORE)	1
56	REAR BASE	1
57	TAPPING SCREW (W/FLANGE) D4x16	4
58	STAND	1
59	SPRING	1
60-1	BATTERY (BSL14 SERIES)	2
60-2	BATTERY (BSL18 SERIES)	2
502	BOX WRENCH 10MM	1
503	GUIDE	1
504	STOPPER SCREW M5x14	1
505	BLADE SHARPENING	1
506	CASE	1
507	SET GAUGE	1
508	BATTERY COVER	2
509	CHARGER (MODEL UC18YFSU/JCT18YSL3)	1
511	CASE ASSY (STACKABLE) INCLUD. 512-514	1
512	LATCH	4
513	HANDLE	4
514	HINGE	2
515	BOTTOM CUSHION	1

Item No.	Part Name	QTY
1	CUTTER BLOCK ASSY (W/B.B.)	1
2	PLANNER BLADES	2
3	SET PLATE (B)	2
4	SET PLATE (A)	2
5	WASHER M4	4
6	MACHINE SCREW M4x5	4
7	BLADE HOLDER	2
8	BOLT M6	6
9	PLANNER BLADES 82MM	2
17	BALL BEARING 608VV/C2PS2L	2
19	BALL BEARING 6200V/CMP2L	2
20	SCREW PLATE	1
21	TAPPING SCREW D4x16	1
22	SPRING	1
23	RUBBER PACKING	1
24	FRONT BASE	1
25	SPRING (F)	1
26	KNOB	1
27	KNOB (A)	1
28	LOCK NUT M10	1
29	KNOB (B)	1
30	WASHER (B)	1
31	NAME PLATE	1
32	TIP COVER	1
33	MACHINE SCREW M4x16	3
34	BRUSH CAP	2
35	CARBON BRUSH	2
36	BEARING COVER	1
37	TAPPING SCREW (W/FLANGE) D4x12	2
38	TAPPING SCREW (W/FLANGE) D4x20	11
39	TAIL COVER	1
40	BRUSH HOLDER	1
41	BRUSH HOLDER (W/FERRITE CORE)	1
42	BELT COVER	1
43	BELT	1
44	PULLY (B)	1
45	END BRACKET	1
46	ARMATURE DC 14.4V	1
47	FAN GUIDE	1
48	MAGNET	1
49	PULLY (A)	1
50	HANDLE COVER	1
51	SWITCH (1P SCREW TYPE) W/O LOCK	1
52	HEX. HD. TAPPING SCREW D4x60	2
53	WASHER	2
54	HOUSING	1

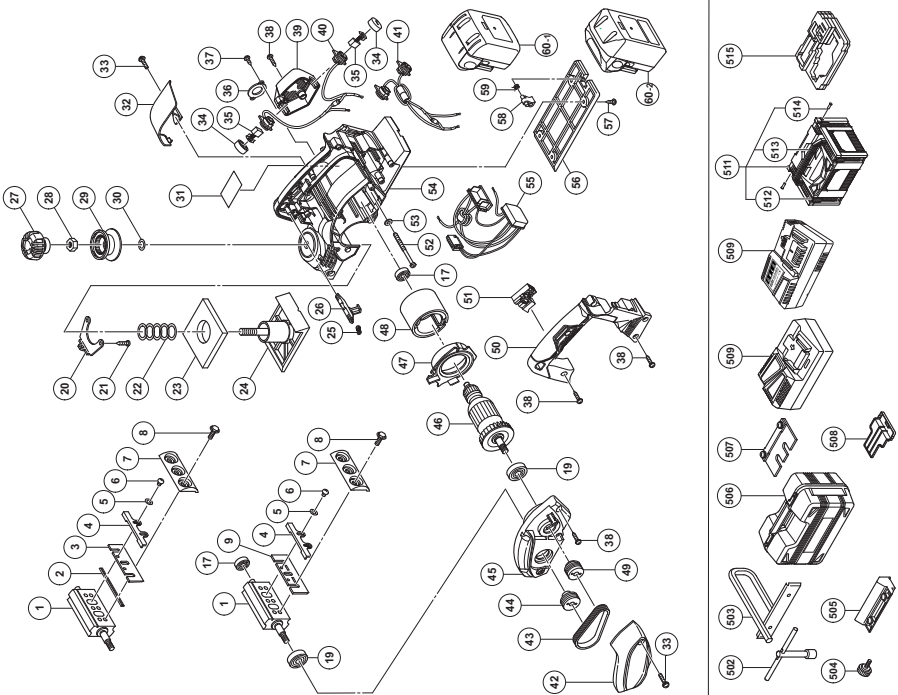

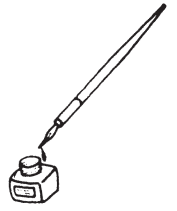

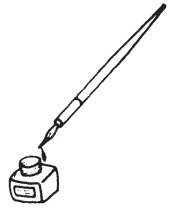

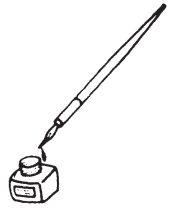

Koki Holdings Co., Ltd.

Shinagawa Intercity Tower A, 15-1, Konan 2-chome,
Minato-ku, Tokyo, Japan