

ELECTRIC TOOL PARTS LIST

■ DUST COLLECTION CIRCULAR SAW 2000·9·10
Model C 7YA (E1)

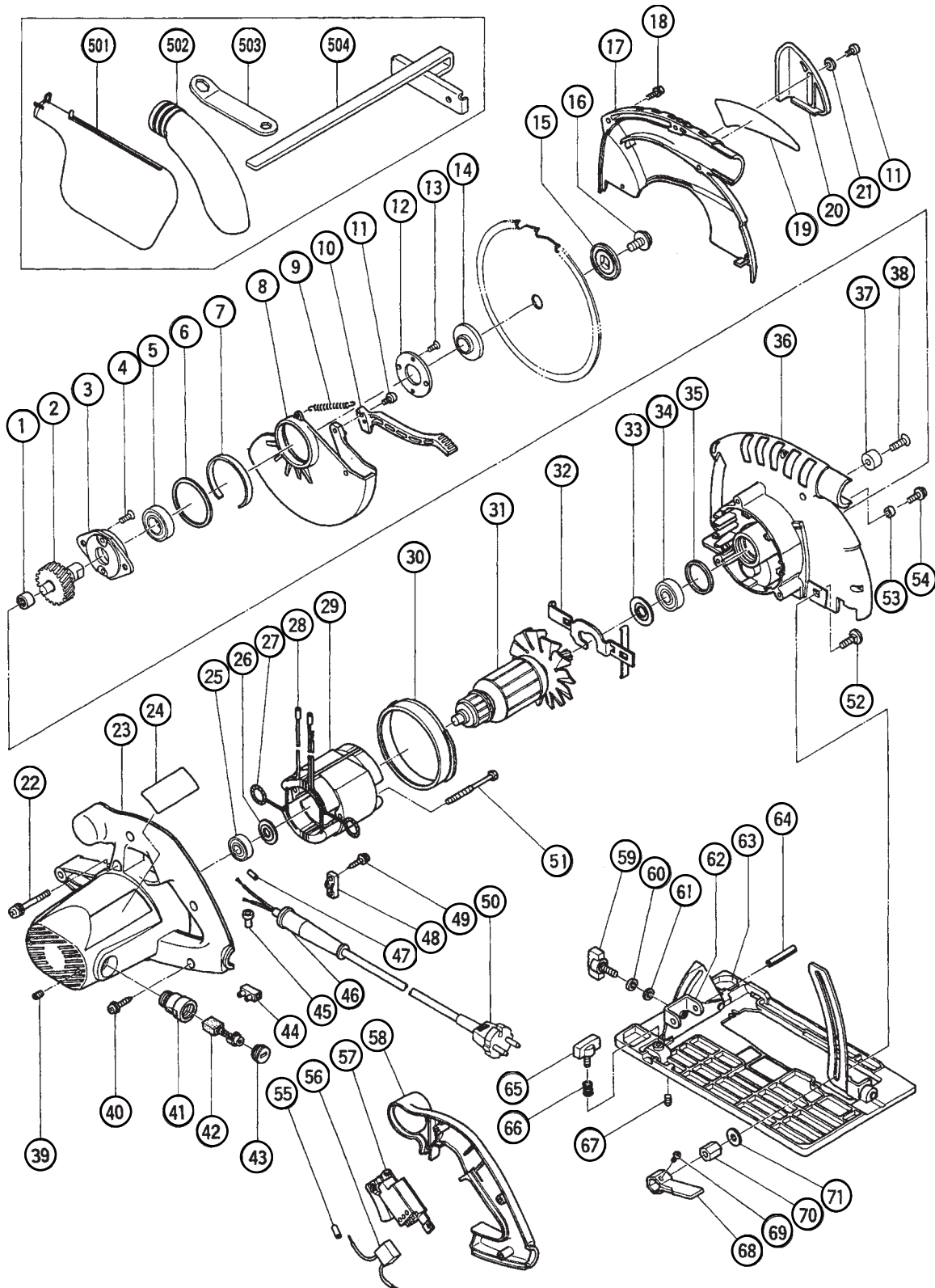

PARTS

C 7YA

ITEM NO.	CODE NO.	DESCRIPTION	NO. USED	REMARKS	
1	982-027	NEEDLE BEARING (HK1010)	1		
2	302-436	SPINDLE AND GEAR SET	1		
3	302-433	BEARING HOLDER	1		
4	992-013	SEAL LOCK FLAT HD. SCREW M5X14	2		
5	600-3VV	BALL BEARING 6003VVCMP2L	1		
6	319-524	WASHER	1		
7	961-807	BUSHING	1		
8	319-291	SAFETY COVER	1		
9	319-523	RETURN SPRING	1		
10	319-292	LEVER	1		
11	958-523	MACHINE SCREW (W/SP. WASHER) M4X8	2		
12	302-435	BEARING COVER	1		
13	990-430	SEAL LOCK FLAT HD. SCREW M4X10	2		
* 14	302-444	WASHER (A)	1		
* 14	302-443	WASHER (A)	1	FOR USA,CAN	
15	302-423	WASHER (B)	1		
16	302-427	BOLT (W/FLANGE) M8X15.5	1		
17	319-288	SAW COVER	1		
18	951-039	MACHINE SCREW (W/SP. WASHER) M4X12	4		
19		HITACHI LABEL	1		
20	319-289	SLIDE COVER	1		
21	319-290	WASHER	1		
22	302-434	MACHINE SCREW (W/WASHERS) M5X45 (BLACK)	3		
23	302-421	HOUSING ASS'Y	1	INCLUD.39,41	
* 24		NAME PLATE	1		
25	600-0VV	BALL BEARING 6000VVCMP2L	1		
26	302-428	WASHER (A)	1		
27	937-623	BRUSH TERMINAL	1		
* 28	981-373	TUBE (D)	1	FOR USA,CAN	
* 29	340-199C	STATOR ASS'Y 110V-115V	1	INCLUD.27,28	
* 29	340-199G	STATOR ASS'Y 220V-230V	1	INCLUD.27	
* 29	340-199F	STATOR ASS'Y 240V	1	INCLUD.27	
30	302-430	FAN GUIDE	1		
* 31	360-187U	ARMATURE ASS'Y 110V-115V	1	INCLUD.25,26,33,34	
* 31	360-187E	ARMATURE 220V-230V	1		
* 31	360-187F	ARMATURE 240V	1		
32	302-431	LOCK LEVER	1		
33	302-429	DUST WASHER (B)	1		
34	620-1VV	BALL BEARING 6201VVCMP2L	1		
35	302-432	RUBBER RING	1		
36	319-287	GEAR COVER	1		
37	961-729	CUSHION	1		
38	949-794	FLAT HD. SCREW M6X20 (10 PCS.)	1		
39	938-477	HEX. SOCKET SET SCREW M5X8	2		
40	301-653	TAPPING SCREW (W/FLANGE) D4X20 (BLACK)	3		
41	983-362	BRUSH HOLDER	2		
42	999-038	CARBON BRUSH (1 PAIR)	2		
43	961-781	BRUSH CAP	2		
* 44	938-307	PILLAR TERMINAL	1	FOR AUS,USA,CAN	
* 45	959-140	CONNECTOR 50091 (10 PCS.)	1	FOR NZL	
* 46	958-049	CORD ARMOR D8.2	1		

* : ALTERNATIVE PARTS

9 - 00

