

ELECTRIC TOOL PARTS LIST

CORDLESS DRIVER DRILL
Model DB 3DL2

2010·6·14
(E1)

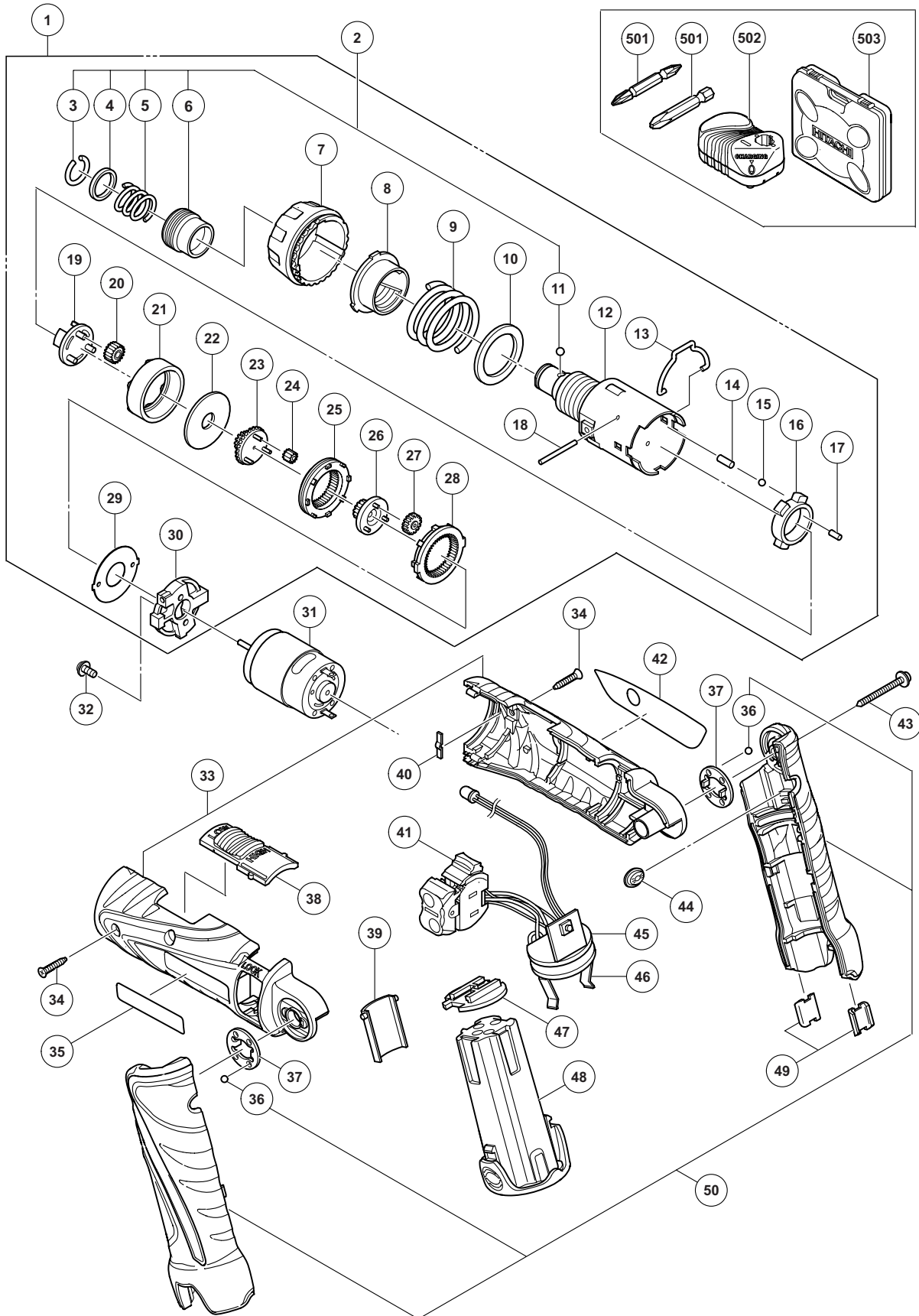

PARTS

DB 3DL2

| ITEM NO. | CODE NO. | DESCRIPTION | NO. USED | REMARKS | |
|----------|----------|-------------|--|---------|--------------------------------|
| * | 1 | 332-759 | GEAR BOX ASS'Y | 1 | INCLUD. 3-30 |
| * | 1 | 332-758 | GEAR BOX ASS'Y | 1 | INCLUD. 3-30 FOR CHN, SIN, VIE |
| | 2 | 320-085 | GUIDE SLEEVE SET | 1 | INCLUD. 3-6, 11 |
| | 3 | 315-984 | RETAINING RING | 1 | |
| | 4 | 315-983 | WASHER (D) | 1 | |
| | 5 | 320-409 | GUIDE SPRING | 1 | |
| | 6 | 319-921 | GUIDE SLEEVE (A) | 1 | |
| | 7 | 332-762 | CLUTCH DIAL | 1 | |
| | 8 | 326-341 | NUT | 1 | |
| | 9 | 326-340 | SPRING | 1 | |
| | 10 | 326-339 | WASHER (D) | 1 | |
| | 11 | 319-535 | STEEL BALL D3.5 (10 PCS.) | 1 | |
| * | 12 | 332-761 | GEAR CASE | 1 | |
| * | 12 | 332-760 | GEAR CASE | 1 | FOR CHN, SIN, VIE |
| | 13 | 326-345 | SHIFT ARM | 1 | |
| | 14 | 326-338 | PIN SET (3 PCS.) | 3 | |
| | 15 | 317-788 | STEEL BALL D3 | 3 | |
| | 16 | 326-323 | LOCK RING | 1 | |
| | 17 | 326-324 | NEEDLE ROLLER SET (6PCS.) | 6 | |
| | 18 | 326-329 | NEEDLE | 2 | |
| | 19 | 326-325 | CARRIER | 1 | |
| | 20 | 326-327 | PLANET GEAR (C) SET (3 PCS.) | 3 | |
| | 21 | 326-326 | RING GEAR | 1 | |
| | 22 | 326-328 | WASHER (B) | 2 | |
| | 23 | 332-768 | PINION (C) | 1 | |
| | 24 | 332-766 | PLANET GEAR (B) SET (3 PCS.) | 3 | |
| | 25 | 332-767 | SLIDE RING GEAR | 1 | |
| | 26 | 332-765 | PINION (B) | 1 | |
| | 27 | 326-335 | PLANET GEAR (A) SET (3 PCS.) | 3 | |
| | 28 | 326-334 | FIRST RING GEAR | 1 | |
| | 29 | 332-764 | WASHER (A) | 1 | |
| | 30 | 332-763 | MOTOR SPACER | 1 | |
| | 31 | 332-755 | MOTOR DC 3.6V | 1 | |
| | 32 | 330-755 | MACHINE SCREW (W/SP. WASHER) M2.6 X 6 | 2 | |
| | 33 | 332-754 | HOUSING (A). (B) SET | 1 | |
| | 34 | 984-319 | PAN HD. TAPPING SCREW D3 X 8 | 4 | |
| | 35 | | HITACHI LABEL | 1 | |
| | 36 | 317-788 | STEEL BALL D3 | 4 | |
| | 37 | 326-315 | CLICK PLATE | 2 | |
| | 38 | 332-757 | SHIFT KNOB | 1 | |
| | 39 | 332-975 | HANDLE COVER | 1 | |
| | 40 | 326-309 | CLICK SPRING | 1 | |
| | 41 | 332-769 | SWITCH (W/LOCK) | 1 | |
| | 42 | | NAME PLATE | 1 | |
| | 43 | 302-086 | TAPPING SCREW (W/FLANGE) D4 X 20 (BLACK) | 1 | |
| | 44 | 332-756 | BUTTON | 1 | |
| | 45 | 332-770 | PRINTED CIRCUIT BOARD | 1 | |
| | 46 | 332-771 | TERMINAL | 2 | |
| | 47 | 326-316 | TERMINAL SUPPORT | 1 | |
| * | 48 | 326-299 | BATTERY EBM 315 (EUROPE, AUS, NZL) | 2 | |

STANDARD ACCESSORIES

DB 3DL2

| ITEM NO. | CODE NO. | DESCRIPTION | NO. USED | REMARKS |
|----------|----------|----------------------------|----------|-------------------|
| * 501 | 992-671 | + DRIVER BIT (B) NO. 2 50L | 1 | |
| * 501 | 983-006 | + DRIVER BIT NO. 2 65L | 1 | FOR CHN, SIN, VIE |
| 502 | | CHARGER (MODEL UC 3SFL) | 1 | |
| 503 | 332-844 | CASE | 1 | |
| | | | | |
| | | | | |
| | | | | |
| | | | | |
| | | | | |
| | | | | |

OPTIONAL ACCESSORIES

| ITEM NO. | CODE NO. | DESCRIPTION | NO. USED | REMARKS |
|----------|----------|-----------------------------------|----------|------------------|
| 601 | 326-665 | HOLSTER | 1 | |
| 602 | 992-670 | + DRIVER BIT (B) NO. 1 50L | 1 | |
| 603 | 992-672 | + DRIVER BIT (B) NO. 3 50L | 1 | |
| 604 | 992-675 | - DRIVER BIT (B) 4MM X 50 | 1 | |
| 605 | 992-676 | - DRIVER BIT (B) 5MM X 50 | 1 | |
| 606 | 992-677 | - DRIVER BIT (B) 6MM X 50 | 1 | |
| 607 | 321-823 | DRILL CHUCK AND ADAPTER SET | 1 | INCLUD. 608, 609 |
| 608 | 307-543 | CHUCK ADAPTER | 1 | |
| 609 | 987-575 | CHUCK WRENCH FOR 10VLB-D, 10VLR-D | 1 | |
| | | | | |
| | | | | |
| | | | | |
| | | | | |
| | | | | |
| | | | | |
| | | | | |
| | | | | |
| | | | | |
| | | | | |
| | | | | |
| | | | | |
| | | | | |
| | | | | |
| | | | | |
| | | | | |
| | | | | |
| | | | | |
| | | | | |